CBSE Class 10th Mathematics Basic
Sample Paper - 01

Maximum Marks:

Time Allowed: 3 hours

General Instructions:

- a. All questions are compulsory
 - b. The question paper consists of 40 questions divided into four sections A, B, C & D.
 - c. Section A comprises of 20 questions of 1 mark each. Section B comprises of 6 questions of 2 marks each. Section C comprises of 8 questions of 3 marks each. Section D comprises 6 questions of 4 marks each.
 - d. There is no overall choice. However internal choices have been provided in two questions of 1 mark each, two questions of 2 marks each, three questions of 3 marks each and three questions of 4 marks each. You have to attempt only one of the alternatives in all such questions.
 - e. Use of calculators is not permitted.
-

Section A

1. The decimal form of $\frac{5}{8}$ is:

- a. 0.625
- b. 0.600
- c. 0.750
- d. 0.375

2. What is the number x? The LCM of x and 18 is 36. The HCF of x and 18 is 2.

- a. 1

b. 3

c. 2

d. 4

3. By Euclid' division lemma $x = qy + r$, $x > y$ the value of q and r for $x = 27$ and $y = 5$ are:

a. $q = 5$, $r = 2$

b. cannot be determined

c. $q = 6$, $r = 3$

d. $q = 5$, $r = 3$

4. In the given figure, the measure of $\angle OQP$ is

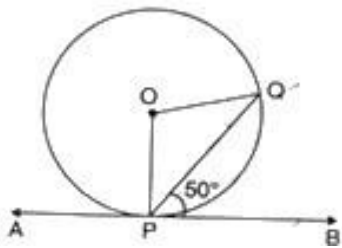

a. 90°

b. 40°

c. 60°

d. 35°

5. The wickets taken by a bowler in 10 cricket matches are 2, 6, 4, 5, 0, 3, 1, 3, 2, 3. The mode of the data is

a. 1

b. 2

c. 4

d. 3

6. The probability that a non leap year will have 53 Fridays and 53 Saturdays is
- 0
 - $\frac{2}{7}$
 - $\frac{3}{7}$
 - $\frac{1}{7}$
7. The zeroes of the polynomial are $x^3 - 2x^2 - x + 2$
- 0, 2, 1
 - 1, 2 and - 1
 - 1, - 2 and - 1
 - 1, - 2 and 1
8. If '3' is a zero of the polynomial $2x^3 - x^2 - 13x - 6$, then the remaining zeroes of the polynomial are
- 2 and 1/2
 - 2 and 1/2
 - 2 and -1/2
 - 2 and -1/2
9. If P(x, y) is any point on the line joining the points A(a, 0) and B(0, b), then
- $\frac{x}{a} - \frac{y}{b} = 0$
 - $\frac{x}{a} + \frac{y}{b} = 1$
 - $\frac{x}{a} + \frac{y}{b} = 0$
 - $\frac{x}{a} - \frac{y}{b} = 1$
10. The distance between the points $A(p \sin 25^\circ, 0)$ and $B(0, p \sin 65^\circ)$ is

- a. 0 units
- b. p units
- c. p^2 units
- d. 1 units

11. Fill in the blanks:

The distance between the points $\left(\frac{-6}{5}, -3\right)$ and $\left(-4, \frac{-7}{5}\right)$ is_____.

12. Fill in the blanks:

$a_1x + b_1y + c_1 = 0$, $a_2x + b_2y + c_2 = 0$ are a system of two simultaneous linear equations.

If $\frac{a_1}{a_2} \neq \frac{b_1}{b_2}$, then the system has_____solution.

OR

Fill in the blanks:

The pair of linear equations $y = 0$ and $y = -5$ has_____solutions.

13. Fill in the blanks:

Two angles are said to be_____if their sum is equal to 90° .

14. Fill in the blanks:

If A and B are acute angles and $\sin A = \cos B$, then the value of $(A + B)$ is_____.

15. Fill in the blanks:

If $\triangle ABC \sim \triangle DFE$, $\angle A = 30^\circ$, $\angle C = 50^\circ$, $AB = 5\text{cm}$, $AC = 8\text{cm}$ and $DF = 7.5\text{cm}$, then DE is =_____.

16. Evaluate $\frac{\sec 11^\circ}{\cos 79^\circ}$.

OR

Prove the trigonometric identity:

$$\tan^2 \theta \cos^2 \theta = 1 - \cos^2 \theta$$

17. Two coins of diameter 2 cm and 4 cm respectively are kept one over the other as shown in the figure, find the area of the shaded ring shaped region in square cm.

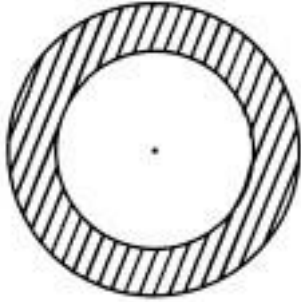

18. A black die and a white die are thrown at the same time. Write all the possible outcomes. What is the probability that the numbers obtained have a product less than 16?
19. A ladder is placed in such a way that its foot is at a distance of 5 m from a wall and its tip reaches a window 12 m above the ground. Determine the length of the ladder.
20. Write the next two terms of the AP: 1, -1, -3, -5,...

Section B

21. Two different dice are tossed together. Find the probability:
- of getting a doublet
 - of getting a sum 10, of the numbers on the two dice.
22. In a family having three children, there may be no girl, two girls or three girls. So, the probability of each is $\frac{1}{4}$. Is this correct? Justify.
23. Find the length of the tangent from a point which is at a distance of 5 cm from the centre of the circle of radius 3 cm.

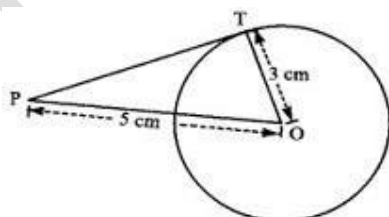

OR

In the given figure, find the perimeter of ABC, if AP = 10 cm.

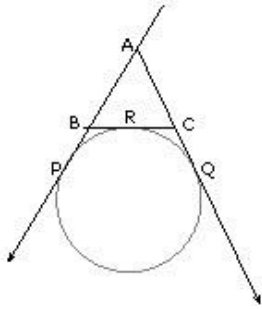

24. If $\tan \theta = \frac{1}{\sqrt{3}}$, then evaluate $\left[\frac{\operatorname{cosec}^2 \theta - \sec^2 \theta}{\operatorname{cosec}^2 \theta + \sec^2 \theta} \right]$

OR

Prove that: $\left(1 + \frac{1}{\tan^2 A} \right) \left(1 + \frac{1}{\cot^2 A} \right) = \frac{1}{(\sin^2 A - \sin^4 A)}$

25. The circumference of two circles are in the ratio 2 : 3. Find the ratio of their areas.

26. A teacher after teaching the chapter polynomial in class 10th, wrote the sum and product of zeroes respectively on the blackboard to test the skill grasped by his students. Find out the polynomials that the teacher has in his mind.

i. 2 and $\sqrt{2}$

ii. $2 - \sqrt{2}$ and $2 - \sqrt{7}$

iii. $\sqrt{3}$ and $-\sqrt{5}$

iv. $\frac{2}{3}$ and $-\frac{1}{2}$

Section C

27. If α, β and γ are zeroes of the polynomial $6x^3 + 3x^2 - 5x + 1$, then find the value of $\alpha^{-1} + \beta^{-1} + \gamma^{-1}$.

28. Construct a $\triangle ABC$ in which $AB = 6.5\text{cm}$, $\angle B = 60^\circ$ and $BC = 5.5\text{ cm}$. Also construct a triangle ABC similar to $\triangle ABC$ whose each side is $\frac{3}{2}$ times the corresponding side of the $\triangle ABC$.

OR

Draw a circle of radius 3 cm. Draw a tangent to the circle making an angle of 30° with a line passing through the centre.

29. A cone of maximum size is curved out from a cube edge 14 cm. Find the surface area of remaining solid after the cone is curved out.
30. Without using trigonometric tables, evaluate the following:

$$\frac{-\tan \theta \cot(90^\circ - \theta) + \sec \theta \operatorname{cosec}(90^\circ - \theta) + \sin^2 35^\circ + \sin^2 55^\circ}{\tan 10^\circ \tan 20^\circ \tan 30^\circ \tan 70^\circ \tan 80^\circ}$$

OR

If $\sin 3\theta = \cos(\theta - 6^\circ)$, where 3θ and $\theta - 6^\circ$ are both acute angles, find the value of θ .

31. If $(x-3)$ is the HCF of $x^3 - 2x^2 + px + 6$ and $x^2 - 5x + q$, find $6p + 5q$

OR

Prove that $\sqrt{5} + \sqrt{3}$ is irrational number.

32. The radii of two concentric circles are 13 cm and 8 cm. AB is a diameter of the bigger circle. BD is a tangent to the smaller circle touching it at D. Find the length of AD.
33. In Green Park, New Delhi Ramesh is having a rectangular plot ABCD as shown in the following figure. Sapling of Gulmohar is planted on the boundary at a distance of 1 m from each other. In the plot, Ramesh builds his house in the rectangular area PQRS. In the remaining part of plot, Ramesh wants to plant grass.

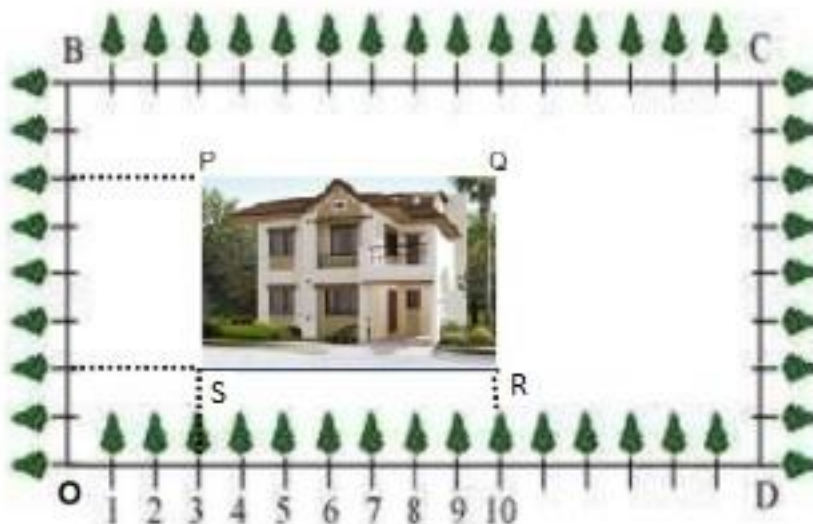

- i. Find the coordinates of vertices P, Q, R and S of rectangle PQRS.
- ii. Find the coordinates of mid-point of diagonal QS.
- iii. What is the area of rectangle PQRS?

34. Find the value of k for which the following pair of linear equations has infinitely many solutions: $2x - 3y = 7$, $(k + 1)x + (1 - 2k)y = (5k - 4)$.

Section D

35. Two pipes running together can fill a tank in $11\frac{1}{9}$ minutes. If one pipe takes 5 minutes more than the other to fill the tank, find the time in which each pipe would fill the tank separately.
36. Find the sum of all integers between 1 and 500 which are multiples of 2 as well as of 5.

OR

A manufacturer of TV sets produced 600 units in the third year and 700 units in the seventh year. Assuming that the production increases uniformly by a fixed number every year. Find the production in

- i. The first year
 - ii. The 10th year
 - iii. 7 years.
37. A tower is $100\sqrt{3}$ meters high. Find the angle of elevation if its top from a point 100 metres away from its foot.
38. In a $\triangle ABC$, let P and Q be points on AB and AC respectively such that $PQ \parallel BC$. Prove that the median AD bisects PQ.

OR

In $\triangle ABC$, AD is a median. Prove that $AB^2 + AC^2 = 2AD^2 + 2DC^2$.

39. Rahul, an engineering student, prepared a model, shaped like a cylinder with two cones attached at its two ends. The diameter of the model is 3 cm and its length is 12 cm. If each conical part has a height of 2 cm, find the cost of painting the outer surface

of the model at Rs.12.50 per cm^2 .

OR

A toy is in the form of a cylinder of diameter $2\sqrt{2}m$ and height 3.5 m surmounted by a cone whose vertical angle is 90° . Find total surface area of the toy.

40. A survey regarding the heights (in cm) of 50 girls of a class was conducted and the following data was obtained:

Height(in cm)	120 - 130	130 - 140	140 - 150	150 - 160	160 - 170	170 - 180
Number of girls	2	8	12	20	8	50

Find the mean, median and mode of the above data.

CBSE Class 10th Mathematics Basic
Sample Paper - 01

Solution

Section A

1. (a) 0.625

Explanation:

Use long division:

$$\begin{array}{r} 0.625 \\ 8 \overline{) 5.0000} \\ \underline{48} \\ 20 \\ \underline{40} \\ 0 \end{array}$$

Thus ' $\frac{5}{8} = 0.625$ '.

2. (d) 4

Explanation:

We know that $\text{LCM} \times \text{HCF} = \text{First number} \times \text{Second number}$

$$\text{HCF}(x, 18) \times \text{LCM}(x, 18) = x \times 18$$

$$2 \times 36 = x \times 18$$

$$\therefore x = \frac{36 \times 2}{18} = 4$$

3. (a) $q = 5, r = 2$

Explanation:

$$x = qy + r$$

$$\Rightarrow 27 = 5 \times 5 + 2$$

$$\Rightarrow q = 5, r = 2$$

4. (b) 40°

Explanation:

Here $\angle OPB = 90^\circ$ [Angle between tangent and radius through the point of contact]

$$\Rightarrow \angle OPQ + \angle QPB = 90^\circ$$

$$\Rightarrow \angle OPQ + 50^\circ = 90^\circ$$

$$\Rightarrow \angle OPQ = 40^\circ \text{ But } \angle OPQ = \angle OQP$$

[Angle opposite to equal radii]

$$\therefore \angle OQP = 40^\circ$$

5. (d) 3

Explanation:

In the given data, the frequency of 3 is more than those other wickets taken by a bowler.

Therefore, Mode of given data is 3.

6. (a) 0

Explanation:

Non-leap year contains 366 days = 52 weeks + 1 day

52 weeks contain 52 Fridays and 52 weeks contain 52 Saturdays

We will get 53 Fridays or 53 Saturdays if remaining one day is a Friday and Saturday

Therefore, Total possibility is zero.

Number of Total possible outcomes = 7

Number of possible outcomes Friday and Saturday = 0

$$\text{Required Probability} = \frac{0}{7} = 0$$

7. (b) 1, 2 and -1

Explanation:

$$\text{Given } p(x) = x^3 - 2x^2 - x + 2$$

$$\Rightarrow p(1) = 1^3 - 2 \times 1^2 - 1 + 2 = 0$$

$$\text{Therefore, } x = 1 \Rightarrow (x - 1) \text{ is a factor of } p(x). \therefore p(x) = x^3 - 2x^2 - x + 2 = (x - 1)(x^2 - x - 2)$$

$$\begin{array}{r}
 x^2 - x - 2 \\
 x-1 \overline{) x^3 - 2x^2 - x + 2} \\
 \underline{x^3 - x^2} \\
 -x^2 - x + 2 \\
 \underline{-x^2 + x} \\
 + - \\
 \underline{-2x + 2} \\
 -2x + 2 \\
 \underline{+ -} \\
 0
 \end{array}$$

$$\Rightarrow p(x) = (x-1)[x^2 - 2x + x - 2] = (x-1)[x(x-2) + 1(x-2)]$$

$$\Rightarrow p(x) = (x-1)(x-2)(x+1)$$

\therefore Zeroes of the given polynomial are 1, 2 and -1 .

8. (c) -2 and $-1/2$

Explanation:

$$\text{Given: } p(x) = 2x^3 - x^2 - 13x - 6$$

$$\Rightarrow p(x) = (x-3)(2x^2 + 5x + 2)$$

$$\begin{array}{r}
 2x^2 + 5x + 2 \\
 x-3 \overline{) 2x^3 - x^2 - 13x - 6} \\
 \underline{2x^3 - 6x^2} \\
 5x^2 - 13x - 6 \\
 \underline{5x^2 - 15x} \\
 - + \\
 \underline{2x - 6} \\
 2x - 6 \\
 \underline{- +} \\
 0
 \end{array}$$

$$\Rightarrow p(x) = (x-3)[2x^2 + 4x + x + 2]$$

$$\Rightarrow p(x) = (x-3)[2x(x+2) + 1(x+2)]$$

$$\Rightarrow p(x) = (x-3)(x+2)(2x+1)$$

\therefore Other two zeroes are $x+2=0$ and $2x+1=0$

$$\Rightarrow x = -2 \text{ and } x = -\frac{1}{2}$$

9. (b) $\frac{x}{a} + \frac{y}{b} = 1$

Explanation:

Points A(a, 0), P (x, y) and B(0, b) are three points on a line (given)

then $(x_1 = a, y_1 = 0)$, $(x_2 = x, y_2 = y)$ and $(x_3 = 0, y_3 = b)$

$$\text{therefore } x_1(y_2 - y_3) + x_2(y_3 - y_1) + x_3(y_1 - y_2) = 0$$

$$= a(y - b) + x(b - 0) + 0(0 - y) = 0$$

$$= ay - ab + xb - 0 + 0 = 0, \text{ then dividing by } ab$$

$$\frac{xb}{ab} + \frac{ay}{ab} = 1$$

$$\Rightarrow \frac{x}{a} + \frac{y}{b} = 1$$

10. (b) p units

Explanation:

The distance between point A($p \sin 25^\circ, 0$) and point B($0, p \sin 65^\circ$) =

$$AB = \sqrt{(0 - p \sin 25^\circ)^2 + (p \sin 65^\circ - 0)^2}$$

$$= \sqrt{p^2 \sin^2 25^\circ + p^2 \sin^2 65^\circ}$$

$$= p \sqrt{\sin^2 25^\circ + \sin^2 (90^\circ - 25^\circ)}$$

$$= p \sqrt{\sin^2 25^\circ + \cos^2 25^\circ} [\because \sin(90^\circ - \theta) = \cos \theta]$$

$$= p \text{ units}$$

$$[\because \cos^2 \theta + \sin^2 \theta = 1]$$

11. $\frac{\sqrt{260}}{5}$ units

12. unique OR no

13. complementary

14. 90°

15. DE = 12cm

$$\begin{aligned}
 16. \quad & \frac{\sec 11^\circ}{\cos ec 79^\circ} \\
 &= \frac{\sec(90^\circ - 79^\circ)}{\cos ec 79^\circ} \\
 &= \frac{\cos ec 79^\circ}{\cos ec 79^\circ} = 1 \quad [\sec(90^\circ - \theta) = \cos ec \theta]
 \end{aligned}$$

OR

We have,

$$\begin{aligned}
 \text{LHS} &= \tan^2 \theta \cos^2 \theta \left[\because \tan^2 \theta = \frac{\sin^2 \theta}{\cos^2 \theta} \right] \\
 &= \sin^2 \theta \\
 &= 1 - \cos^2 \theta \left[\because \sin^2 \theta = 1 - \cos^2 \theta \right] \\
 &= \text{RHS}
 \end{aligned}$$

Hence proved.

$$\begin{aligned}
 17. \quad & d_1 = 2 \text{ cm and } d_2 = 4 \text{ cm} \\
 & r_1 = \frac{2}{2} = 1 \text{ cm and } r_2 = \frac{4}{2} = 2 \text{ cm}
 \end{aligned}$$

$$\text{Area of circle} = \pi r^2$$

$$\text{Area of the shaded region} = \pi r_2^2 - \pi r_1^2$$

$$\therefore \text{Area of the shaded region} = \pi(2)^2 - \pi(1)^2$$

$$4\pi - \pi = 3\pi \text{ sqcm}$$

18. Consider the set of ordered pairs

{(1,1)(1,2)(1,3)(1,4)(1,5)(1,6)

(2,1)(2,2)(2,3)(2,4)(2,5)(2,6)

(3,1)(3,2)(3,3)(3,4)(3,5)(3,6)

(4,1)(4,2)(4,3)(4,4)(4,5)(4,6)

(5,1)(5,2)(5,3)(5,4)(5,5)(5,6)}

Clearly, there are 36 elementary events.

$$\therefore n(\text{Total number of throws}) = 36$$

Number of pairs such that the numbers obtained have a product less than 16 can be selected as listed below:

{(1,1)(1,2)(1,3)(1,4)(1,5)(1,6)

(2,1)(2,2)(2,3)(2,4)(2,5)(2,6)

(3,1)(3,2)(3,3)(3,4)(3,5)

(4,1)(4,2)(4,3)

(5,1)(5,2)(5,3)

(6,1)(6,2)}

Therefore, $n(\text{Favourable events}) = 25$

$P(\text{the number obtained appearing have a product less than } 16) =$

$$\frac{\text{number obtained have a product less than } 16}{\text{Total number throws}} = \frac{25}{36}$$

19. Let AC be the ladder, AB be the wall and BC be the distance of ladder from the foot of the wall.

In right $\triangle ABC$,

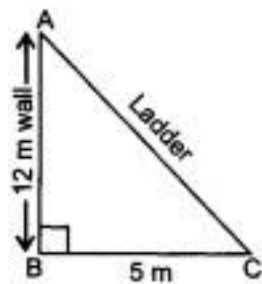

$$AC^2 = AB^2 + BC^2 \{ \text{using Pythagoras theorem for right-angled triangle} \}$$

$$\Rightarrow AC^2 = (12)^2 + 5^2$$

$$\Rightarrow AC^2 = 144 + 25$$

$$\Rightarrow AC = 13 \text{ m}$$

20.1 $a_1 =$

$$d = a_2 - a_1 = -1 - 1 = -2$$

$$a_5 = a_1 + 4d$$

$$= 1 + (4)(-2) = 1 - 8 = -7$$

$$a_6 = a_5 + d = -7 - 2 = -9$$

Next two terms are -7 and -9.

Section B

21. Total number of possible outcomes = 36

i. Doublet are $\{ (1, 1) (2, 2) (3, 3) (4, 4) (5, 5) (6, 6) \}$.

Total number of doublets = 6

$$\therefore \text{Prob (getting a doublet)} = \frac{6}{36} = \frac{1}{6}$$

ii. Outcome whose sum of digits is 10 = {(4, 6) (5, 5) (6, 4)}.

Number of favorable outcomes = 3

$$\therefore \text{Prob (getting a sum 10)} = \frac{3}{36} = \frac{1}{12}$$

22. Total cases are 8.

(GGG), (GGB), (GBG), (GBB), (BGG), (BGB), (BGB), (BBB)

$$\text{No girl} = \frac{1}{8}$$

$$2 \text{ girls} = \frac{3}{8}$$

$$3 \text{ girls} = \frac{1}{8}$$

No, It is not correct.

23. From Figure,

OT = 3 cm, OP = 5 cm [given]

Since, the radius of the circle is perpendicular to the tangent at the point of contact.

$$\therefore \angle OTP = 90^\circ$$

In right triangle OTP, OP is hypotenuse,

$$\therefore OP^2 = OT^2 + TP^2 \text{ [By Pythagoras theorem]}$$

$$\Rightarrow TP^2 = OP^2 - OT^2$$

$$\Rightarrow TP^2 = (5)^2 - (3)^2 = 25 - 9 = 16$$

$$\Rightarrow TP = \sqrt{16} = 4$$

Hence, the length of the tangent is 4 cm.

OR

\therefore BC touches the circle at R

\therefore Tangents drawn from external point to the circle are equal.

$$\therefore AP = AQ, BR = BP$$

And CR = CQ

$$\therefore \text{Perimeter of } \triangle ABC = AB + BC + AC$$

$$= AB + (BR + RC) + AC$$

$$= AB + BP + CQ + AC$$

$$= AP + AQ = 2AP = 2 \times 10 = 20 \text{ cm}$$

24. $\tan \theta = \frac{1}{\sqrt{3}}$

$$\Rightarrow \theta = 30^\circ$$

$$\begin{aligned} \frac{\operatorname{cosec}^2 \theta - \sec^2 \theta}{\operatorname{cosec}^2 \theta + \sec^2 \theta} &= \frac{\operatorname{cosec}^2 30^\circ - \sec^2 30^\circ}{\operatorname{cosec}^2 30^\circ + \sec^2 30^\circ} \\ &= \frac{(2)^2 - \left(\frac{2}{\sqrt{3}}\right)^2}{(2)^2 + \left(\frac{2}{\sqrt{3}}\right)^2} \\ &= \frac{4 - \frac{4}{3}}{4 + \frac{4}{3}} = \frac{1}{2} \end{aligned}$$

OR

We have,

$$\begin{aligned} \text{L.H.S.} &= \left(1 + \frac{1}{\tan^2 A}\right) \left(1 + \frac{1}{\cot^2 A}\right) \\ &= (1 + \cot^2 A)(1 + \tan^2 A) = \operatorname{cosec}^2 A \cdot \sec^2 A \\ &= \frac{1}{\sin^2 A} \cdot \frac{1}{\cos^2 A} = \frac{1}{\sin^2 A \cos^2 A} \\ &= \frac{1}{\sin^2 A (1 - \sin^2 A)} = \frac{1}{(\sin^2 A - \sin^4 A)} = \text{R.H.S.} \end{aligned}$$

\therefore L.H.S. = R.H.S.

Hence Proved.

25. Let radius of first circle = x cm

radius of second circle = y cm

$$\text{Given, } \frac{\text{Circumference of first circle}}{\text{Circumference of second circle}} = \frac{2}{3}$$

$$\Rightarrow \frac{2\pi(x)}{2\pi(y)} = \frac{2}{3}$$

$$\Rightarrow \frac{x}{y} = \frac{2}{3} \dots\dots \text{(i)}$$

$$\text{Now, } \frac{\text{Area of first circle}}{\text{Area of second circle}} = \frac{\pi(x)^2}{\pi(y)^2}$$

$$= \frac{x^2}{y^2}$$

$$= \left(\frac{x}{y}\right)^2$$

$$= \left(\frac{2}{3}\right)^2 \text{ [from (i)]}$$

$$= \frac{4}{9} = 4 : 9$$

26. i. Quadratic polynomial is $x^2 - (\text{sum of zeros})x + \text{product of zeros}$

$$\therefore \text{Required polynomial} = x^2 - (2)x + \sqrt{2} = x^2 - 2x + \sqrt{2}$$

ii. Quadratic polynomial is $x^2 - (\text{sum of zeros})x + \text{product of zeros}$

- i. Draw a line segment $AB = 6.5\text{cm}$.
- ii. At B construct $\angle ABX = 60^\circ$.
- iii. With B as centre and radius $BC = 5.5\text{cm}$ draw an arc intersecting BX at C.
- iv. Join AC. Triangle so obtained is the required triangle.
- v. Construct an acute angle $\angle BAY$ at A on opposite side of vertex C of $\triangle ABC$.
- vi. Locate 3 points A_1, A_2, A_3 on AY such that $AA_1 = A_1A_2 = A_2A_3$.
- vii. Join A_2 to B and draw the line through A_3 parallel to A_2B intersecting the extended line segment AB at B' .
- viii. Draw a line through B' parallel to BC intersecting the extended line segment AC at C' .
- ix. $\triangle AB'C'$ so obtained is the required triangle

OR

Steps of construction:

1. Draw a circle with center O and radius 3 cm.
2. Draw radius OA and produce it to B.
3. Make $\angle AOP = 60^\circ$.
4. Draw PQ perpendicular to OP, meeting OB at Q.
5. Then, PQ is the desired tangent, such that $\angle OQP = 30^\circ$.

Construction:

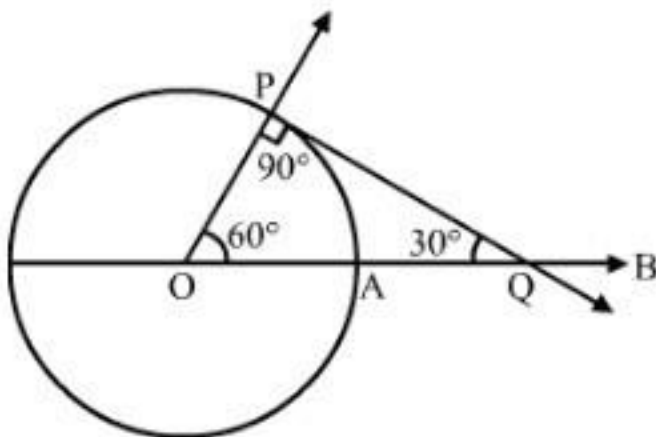

29. Edge of the cube = 14 cm

Cone of maximum size is curved from the cube

∴ Diameter of base of the cone = Edge of the cube = 14 cm

Radius of cone = 7 cm

Let 'h' be the height of the cone

Height of the cone, h = edge of the cube = 14cm

Therefore, Slant height, $l = \sqrt{h^2 + r^2} = \sqrt{14^2 + 7^2}$

$$= \sqrt{196 + 49} = \sqrt{245}$$

$$= 15.65 \text{ cm}$$

Slant height = 15.65cm

Total surface area of the remaining solid = Total Surface area of the cube + Curved Surface area of cone - Circular area of base of cone

$$= 6a^2 + \pi rl - \pi r^2$$

$$= 6 \times 14 \times 14 + \frac{22}{7} \times 7 \times 15.65 - \frac{22}{7} \times 7 \times 7$$

$$= 1176 + [22(15.65 - 7)]$$

$$= 1176 + (22 \times 8.65)$$

$$= 1366.3 \text{ cm}^2$$

Total surface area of the remaining solid = 1366.3cm²

30. We have,

$$\begin{aligned} & \frac{-\tan \theta \cot(90^\circ - \theta) + \sec \theta \operatorname{cosec}(90^\circ - \theta) + \sin^2 35^\circ + \sin^2 55^\circ}{\tan 10^\circ \tan 20^\circ \tan 30^\circ \tan 70^\circ \tan 80^\circ} \\ &= \frac{-\tan \theta \tan \theta + \sec \theta \sec \theta + \sin^2 35^\circ + \sin^2(90^\circ - 35^\circ)}{\tan 10^\circ \tan 20^\circ \tan 30^\circ \tan(90^\circ - 20^\circ) \tan(90^\circ - 10^\circ)} \quad [\text{since } \cot(90^\circ - A) = \tan A, \operatorname{cosec}(90^\circ - A) \\ &= \sec A] \\ &= \frac{-\tan^2 \theta + \sec^2 \theta + \sin^2 35^\circ + \cos^2 35^\circ}{\tan 10^\circ \tan 20^\circ \tan 30^\circ \cot 20^\circ \cot 10^\circ} \quad [\text{since, } \sin(90^\circ - A) = \cos A, \tan(90^\circ - A) = \cot A] \\ &= \frac{(\sec^2 \theta - \tan^2 \theta) + (\cos^2 35^\circ + \sin^2 35^\circ)}{(\tan 10^\circ \cot 10^\circ)(\tan 20^\circ \cot 20^\circ) \times \frac{1}{\sqrt{3}}} = \frac{1+1}{1 \times 1 \times \frac{1}{\sqrt{3}}} \quad [\text{since, } \sin^2 A + \cos^2 A = 1] \end{aligned}$$

$$= 2\sqrt{3}$$

OR

Given,

$$\sin 3\theta = \cos (\theta - 6^\circ)$$

$$\cos (90^\circ - 3\theta) = \cos (\theta - 6^\circ)$$

$$90^\circ - 3\theta = \theta - 6^\circ$$

$$4\theta = 90^\circ + 6^\circ = 96^\circ$$

$$\therefore \theta = \frac{96^\circ}{4} = 24^\circ$$

31. Here, $x - 3$ is the HCF of

$$x^3 - 2x^2 + px + 6 \text{ and } x^2 - 5x + q$$

Since $x - 3$ is a common factor of given expression

$f(x) = x^3 - 2x^2 + px + 6$, then by factor theorem

$$f(x) = 0$$

$$\Rightarrow 3^3 - 2 \times 3^2 + p \times 3 + 6 = 0$$

$$\Rightarrow 27 - 18 + 3p + 6 = 0 \Rightarrow 15 + 3p = 0$$

$$\Rightarrow 3p = -15 \Rightarrow p = \frac{-15}{3} = -5$$

Since $x - 3$ is a factor of $g(x) = x^2 - 5x + q$,

then by factor theorem, $g(3) = 0$

$$\Rightarrow 3^2 - 5 \times 3 + q = 0 \Rightarrow 9 - 15 + q = 0$$

$$\Rightarrow -6 + q = 0 \Rightarrow q = 6$$

$$\therefore 6p + 5q = 6 \times (-5) + 5 \times 6$$

$$= -30 + 30 = 0$$

$$\text{Hence } 6p + 5q = 0$$

OR

Let $\sqrt{5} + \sqrt{3}$ be rational number equal to $\frac{a}{b}$. there exist co-prime integers a and b such that

$$\sqrt{5} + \sqrt{3} = \frac{a}{b}$$

$$\Rightarrow \sqrt{5} = \frac{a}{b} - \sqrt{3}$$

$$\Rightarrow (\sqrt{5})^2 = \left(\frac{a}{b} - \sqrt{3}\right)^2 \quad [\text{Squaring both sides}] \text{ we get,}$$

$$\Rightarrow 5 = \frac{a^2}{b^2} - \frac{2a\sqrt{3}}{b} + 3$$

$$\Rightarrow 2 = \frac{a^2}{b^2} - \frac{2\sqrt{3}a}{b}$$

$$\sqrt{3} = (a^2 - 2b^2) \frac{b}{2ab}$$

Since a, b are integers, therefore $(a^2 - 2b^2) \frac{b}{2ab}$ is a rational number which is a contradiction as $\sqrt{3}$ is an irrational number.
Hence, $\sqrt{5} + \sqrt{3}$ is irrational.

32. Produce BD to meet the bigger circle at E . Join AE .

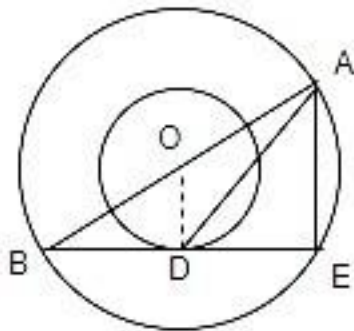

Then, $\angle AEB = 90^\circ$ [angle in semi-circle]

Clearly, $OD \perp BE$

Now, in $\triangle AEB$, O and D are the mid-points of AB and BE , respectively.

Therefore, by mid-point theorem, we have

$$OD = \frac{1}{2}AE$$

$$\Rightarrow AE = 2 \times 8 = 16 \text{ cm} \text{ [OD = radius of smaller circle = 8 cm]}$$

In right-angled $\triangle ODB$,

$$OB^2 = OD^2 + BD^2 \text{ [By pythagoras theorem]}$$

$$\Rightarrow BD^2 = 169 - 64 = 105$$

$$\Rightarrow BC = \sqrt{105} \text{ cm} = DE \text{ [BD = DE]}$$

Now, in right-angled $\triangle AED$,

$$AD^2 = AE^2 + ED^2 \text{ [by pythagoras theorem]}$$

$$\Rightarrow AD = \sqrt{(16)^2 + (\sqrt{105})^2} = 19 \text{ cm}$$

33. i. The perpendiculars from P, Q, R and S intersect the x -axis at $3, 10, 10$ and 3 respectively.
Also, the perpendiculars from P, Q, R and S intersect the y -axis at $6, 6, 2, 2$ respectively.

Hence coordinates of P, Q, R and S are: P(3, 6), Q(10, 6), R(10, 2) and S(3, 2).

ii. Let M be the mid-point of QS.

So using mid-point formula, Coordinates of M are $(\frac{3+10}{2}, \frac{2+6}{2}) = (\frac{13}{2}, 4)$

iii. Now, $PQ = \sqrt{(10-3)^2 + (6-6)^2} = \sqrt{49} = 7 \text{ m}$

$PS = \sqrt{(3-3)^2 + (2-6)^2} = \sqrt{16} = 4 \text{ m}$

Hence, area of rectangle PQRS = $PQ \times PS = 7 \times 4 = 28 \text{ m}^2$

34. The given equations are

$$2x - 3y - 7 = 0,$$

$$(k+1)x + (1-2k)y + (4-5k) = 0.$$

These equations are of the form

$$a_1x + b_1y + c_1 = 0, a_2x + b_2y + c_2 = 0,$$

where $a_1 = 2, b_1 = -3, c_1 = -7$ and $a_2 = (k+1), b_2 = (1-2k), c_2 = (4-5k)$

Let the given system of equations have infinitely many solutions.

$$\text{Then, } \frac{a_1}{a_2} = \frac{b_1}{b_2} = \frac{c_1}{c_2}$$

$$\Rightarrow \frac{2}{(k+1)} = \frac{-3}{(1-2k)} = \frac{-7}{(4-5k)}$$

$$\Rightarrow \frac{2}{(k+1)} = \frac{3}{(2k-1)} = \frac{7}{(5k-4)}$$

$$\Rightarrow \frac{2}{(k+1)} = \frac{3}{(2k-1)} \text{ and } \frac{3}{(2k-1)} = \frac{7}{(5k-4)}$$

$$\Rightarrow 4k - 2 = 3k + 3 \text{ and } 15k - 12 = 14k - 7$$

$$\Rightarrow k = 5 \text{ and } k = 5.$$

Hence, $k = 5$.

Section D

35. By the question, two pipes running together can fill a tank in $\frac{11}{9}$ minutes. If one pipe takes 5 minutes more than the other to fill the tank, we have to find the time in which each pipe would fill the tank separately.

Let time taken by pipe A be x minutes, and time taken by pipe B be $x + 5$ minutes.

In one minute pipe A will fill $\frac{1}{x}$ tank

In one minute pipe B will fill $\frac{1}{x+5}$ tank

pipes A + B will fill in one minute = $\frac{1}{x} + \frac{1}{x+5}$ tank

Now according to the question.

$$\frac{1}{x} + \frac{1}{x+5} = \frac{9}{100}$$

$$\text{or, } \frac{x+5+x}{x(x+5)} = \frac{9}{100}$$

$$\text{or, } 100(2x + 5) = 9x(x + 5)$$

$$\text{or, } 200x + 500 = 9x^2 + 45x$$

$$\text{or, } 9x^2 - 155x - 500 = 0$$

$$\text{or, } 9x^2 - 180x + 25x - 500 = 0$$

$$\text{or, } 9x(x - 20) + 25(x - 20) = 0$$

$$\text{or, } (x-20)(9x + 25) = 0$$

$$\text{or, } x = 20, \frac{-25}{9}$$

rejecting negative value, $x = 20$ minutes

and $x + 5 = 25$ minutes

Hence pipe A will fill the tank in 20 minutes and pipe B will fill it in 25 minutes.

36. Integers between 1 and 500 which are multiples of 2 as well as 5 are

10, 20, 30,, 490

This forms an A.P. with $a = 10$, $d = 10$, and $l = 490$

Let the number of these terms be n .

Then,

$$a_n = 490$$

$$\Rightarrow a + (n - 1)d = 490$$

$$\Rightarrow 10 + (n - 1)(10) = 490$$

$$\Rightarrow (n - 1)(10) = 480$$

$$\Rightarrow n - 1 = 48$$

$$\Rightarrow n = 49$$

$$\begin{aligned}
\Rightarrow S_{49} &= \frac{49}{2}[2 \times 10 + 48 \times 10] \\
&= \frac{49}{2} \times [20 + 480] \\
&= \frac{49}{2} \times 500 \\
&= 12250
\end{aligned}$$

OR

Since the production increases uniformly by a fixed number every year. Therefore, the sequence formed by the production in different years is an A.P. Let a be the first term and d be the common difference of the A.P. formed i.e., ' a ' denotes the production in the first year and d denotes the number of units by which the production increases every year.

We have, $a_3 = 600$ and $a_7 = 700 \Rightarrow a + 2d = 600$ and $a + 6d = 700$. Solving these equations, we get; $a = 550$ and $d = 25$.

1. We have, $a = 550$

\therefore Production in the first year is of 550 TV sets.

2. The production in the 10th term is given by a_{10} .

Therefore, production in the 10th year $= a_{10} = a + 9d = 550 + 9 \times 25 = 775$. So, production in 10th year is of 775 TV sets.

3. Total production in 7 years

= Sum of 7 terms of the A.P. with first term a ($= 550$) and common difference d ($= 25$).

$$= \frac{7}{2} \{2 \times 550 + (7 - 1) \times 25\}$$

$$= \frac{7}{2} (1100 + 150) = 4375.$$

37. Let AB be the tower of height $100\sqrt{3}$ metres, and let C be a point at a distance of 100 metres from the foot of the tower.

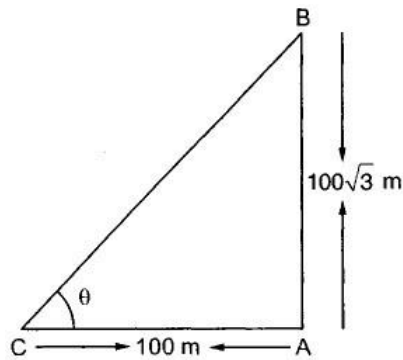

Let θ be the angle of elevation of the top of the tower from point C.

Clearly, in $\triangle CAB$ the lengths of base AC and perpendicular AB are known. So, we will use the trigonometric ratios

In $\triangle CAB$, we have

$$\tan \theta = \frac{AB}{AC}$$

$$\Rightarrow \tan \theta = \frac{100\sqrt{3}}{100} = \sqrt{3}$$

$$\Rightarrow \tan \theta = \tan 60^\circ$$

$$\Rightarrow \theta = 60^\circ$$

Hence, the angle of elevation of the top of the tower from a point 100 metres away from its foot is 60° .

38. We need to prove that the median AD bisects PQ.

Let us suppose the median AD intersects PQ at E.

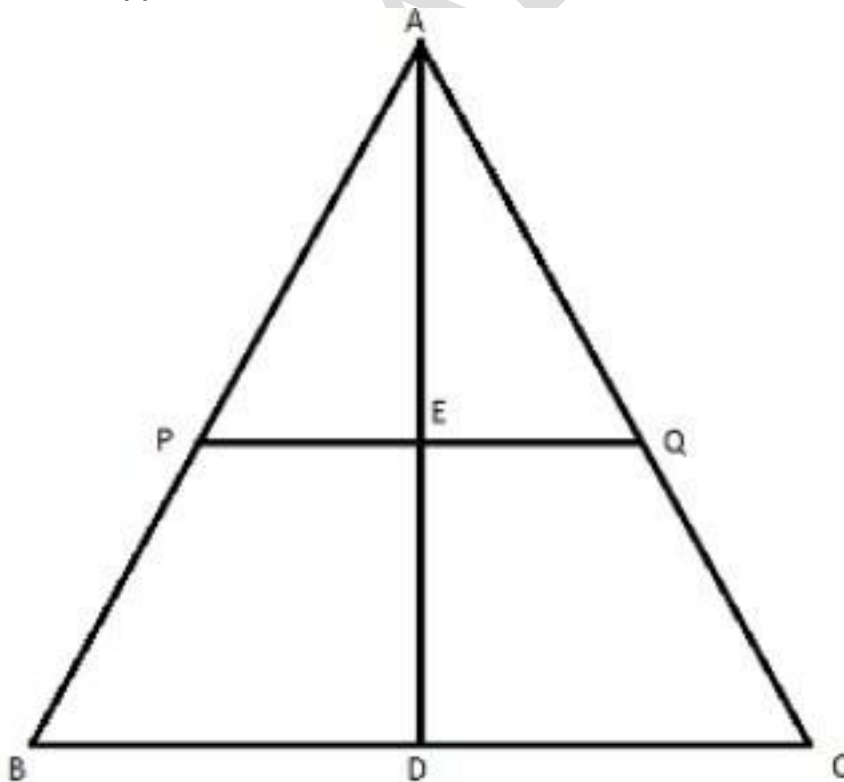

Now, $PQ \parallel BC$

$\Rightarrow \angle APE = \angle B$ and $\angle AQE = \angle C$ [Corresponding angles]

So, in Δ 's APE and ABD, we have

$$\angle APE = \angle ABD$$

and, $\angle PAE = \angle BAD$ [Common]

$\therefore \Delta APE \sim \Delta ABD$

$$\Rightarrow \frac{PE}{BD} = \frac{AE}{AD} \dots\dots\dots(i)$$

Similarly, we have

$\Delta AQE \sim \Delta ACD$

$$\therefore \frac{QE}{CD} = \frac{AE}{AD} \dots\dots\dots(ii)$$

From (i) and (ii), we get

$$\frac{PE}{BD} = \frac{QE}{CD}$$

$$\Rightarrow \frac{PE}{BD} = \frac{QE}{BD} \text{ [}\because \text{AD is the median } \therefore \text{BD} = \text{CD}]$$

$$\Rightarrow PE = QE$$

Hence, AD bisects PQ.

OR

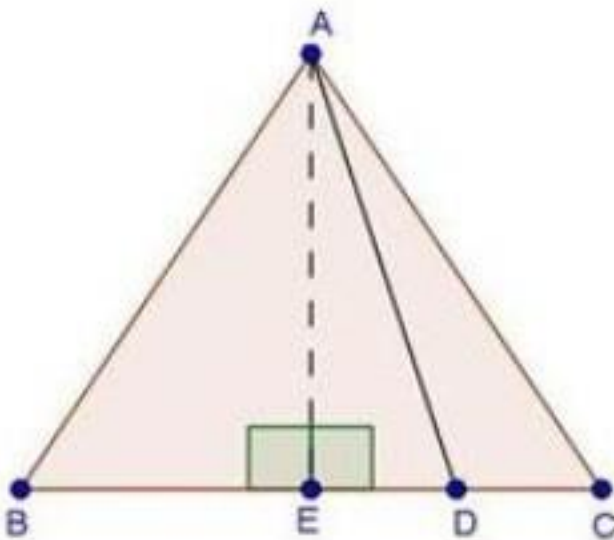

Construction:- Draw $AE \perp$

BC Given, AD is a median

In ΔAED ,

By using pythagoras theorem, we get

$$DE^2 = AE^2 + AD^2$$

$$AE^2 = AD^2 - DE^2 \dots (i)$$

In $\triangle AEB$,

By using pythagoras theorem, we get

$$AB^2 = AE^2 + BE^2$$

$$\Rightarrow AB^2 = AD^2 - DE^2 + (BD - DE)^2 \text{ [from (i)]}$$

$$\Rightarrow AB^2 = AD^2 - DE^2 + BD^2 + DE^2 - 2BD \times DE$$

$$\Rightarrow AB^2 = AD^2 + CD^2 - 2CD \times DE \dots (i) \text{ [BD = CD]}$$

In $\triangle AEC$,

By using pythagoras theorem, we get

$$AC^2 = AE^2 + EC^2$$

$$\Rightarrow AC^2 = AD^2 - DE^2 + (DE + DC)^2 \text{ [from (i)]}$$

$$\Rightarrow AC^2 = AD^2 - DE^2 + DE^2 + DC^2 + 2DE \times DC$$

$$\Rightarrow AC^2 = AD^2 + DC^2 + 2DE \times DC \dots (ii)$$

Add equations (i) and (ii)

$$\text{Therefore, } AB^2 + AC^2 = 2AD^2 + 2CD^2$$

39. Radius of each conical part, $r = \frac{3}{2}$ cm.

Radius of cylindrical part, $r = \frac{3}{2}$ cm.

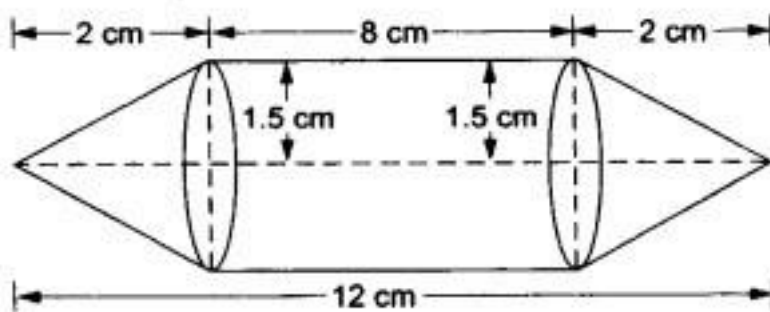

Height of each conical part, $h = 2$ cm.

Length of the cylindrical part, $h = (12 - 2 \times 2)$ cm = 8 cm.

Slant height of each conical part,

$$l = \sqrt{r^2 + h^2} = \sqrt{\left(\frac{3}{2}\right)^2 + 2^2} \text{ cm} = \sqrt{\frac{9}{4} + 4} \text{ cm}$$

$$= \sqrt{\frac{25}{4}} \text{ cm} = \frac{5}{2} \text{ cm.}$$

Total surface area of the model = curved surface area of 2 conical parts + curved surface area of the cylindrical part

$$\begin{aligned}
&= 2 \times \pi r l + 2\pi r H = 2\pi r(l + H) \\
&= \left[2 \times \frac{22}{7} \times \frac{3}{2} \times (2.5 + 8) \right] \text{cm}^2 \\
&= \left(2 \times \frac{22}{7} \times \frac{3}{2} \times 10.5 \right) \text{cm}^2 = 99 \text{cm}^2
\end{aligned}$$

∴ cost of painting the model = Rs. (99 × 12.50)
= Rs. 1237.50.

OR

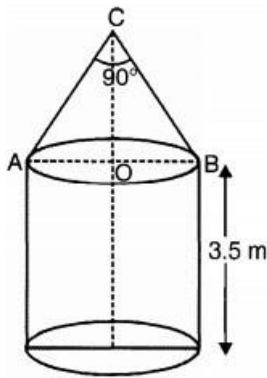

According to question, $\angle C = 90^\circ$

Let, $AC = BC = x$

According to pythagorastheorem,

$$\therefore AB^2 = AC^2 + BC^2$$

$$AB^2 = x^2 + x^2$$

$$\therefore 2x^2 = (2\sqrt{2})^2$$

or, $x = 2\text{m}$

$$r = \sqrt{2}\text{m (given)}$$

Radius of the cylinder = Radius of the cone

∴ Slant height of conical portion, $x = 2\text{ m}$

Total surface area of toy = curved surface area of cylinder + Area of base of cylinder +

Curved surface area of cone

$$= 2\pi r h + \pi r^2 + \pi r l$$

$$= \pi r(2h + r + l)$$

$$= \pi r[7 + \sqrt{2} + 2]m^2$$

$$= \pi\sqrt{2}[9 + \sqrt{2}]m^2$$

$$= \pi[2 + 9\sqrt{2}]m^2$$

$$\text{The total surface area of the toy} = \pi[2 + 9\sqrt{2}]m^2$$

40. Table:

Class	Frequency	Mid value x_i	$u_i = \left(\frac{x_i - A}{h}\right)$	$f_i u_i$	Cumulative Frequency
120 - 130	2	125	-2	-4	2
130 - 140	8	135	-1	-8	10
140 - 150	12	145 = A	0	0	22
150 - 160	20	155	1	20	42
160 - 170	8	165	2	16	50
	N = 50				$\Sigma f_i u_i = 24$

i. Let the assumed mean A be 145. Class interval $h = 10$

$$\text{Mean } (\bar{x}) = A + h \left(\frac{\Sigma f_i u_i}{N} \right)$$

$$= 145 + 10 \times \left(\frac{24}{50} \right)$$

$$= 145 + 4.8 = 149.8$$

ii. $N = 50$; $\frac{N}{2} = \frac{50}{2} = 25$

Cumulative Frequency just after 25 is 42.

Therefore, median class is 150 - 160.

$$l = 150, h = 10, f = 20, c.f. = 22$$

$$\text{Median (M)} = l + h \left(\frac{\frac{N}{2} - c.f.}{f} \right)$$

$$= 150 + 10 \times \left(\frac{25 - 22}{20} \right)$$

$$= 150 + \frac{10 \times 3}{20}$$

$$= 150 + 1.5 = 151.5$$

iii. we know that, Mode = 3 median - 2 mean

$$= 3(151.5) - 2(149.8)$$

$$= 454.5 - 299.6$$

$$= 154.9$$

Thus, Mean = 149.8, Median = 151.5, Mode = 154.9