CBSE Class 10th Mathematics Standard

Sample Paper - 01

Maximum Marks:

Time Allowed: 3 hours

General Instructions:

- i. All the questions are compulsory.
 - ii. The question paper consists of 40 questions divided into 4 sections A, B, C, and D.
 - iii. Section A comprises of 20 questions of 1 mark each. Section B comprises of 6 questions of 2 marks each. Section C comprises of 8 questions of 3 marks each. Section D comprises of 6 questions of 4 marks each.
 - iv. There is no overall choice. However, an internal choice has been provided in two questions of 1 mark each, two questions of 2 marks each, three questions of 3 marks each, and three questions of 4 marks each. You have to attempt only one of the alternatives in all such questions.
 - v. Use of calculators is not permitted.
-

Section A

1. Which of the following numbers have the non-terminating repeating decimal expansion?

a. $\frac{117}{6^2 \times 5^3}$

b. $\frac{6}{15}$

c. $\frac{21}{280}$

d. $\frac{77}{210}$

2. The LCM of 24, 60 and 150 is

- a. 2400
- b. 1800
- c. 600
- d. 1200

3. The percentage of marks obtained by 100 students in an examination are as follows:

Marks	130-135	135-140	140-145	145-150	150-155	155-160	160-165
Frequency	10	15	18	22	23	8	4

The cumulative frequency of the class interval 150 – 155 is

- a. 90
 - b. 80
 - c. 100
 - d. 88
4. In a cricket match Kumble took three wickets less than twice the number of wickets taken by Srinath. The product of the number of wickets taken by these two is 20, then the number of wickets taken by Kumble is
- a. 4
 - b. 5
 - c. 10
 - d. 2
5. If $a \sin \theta + b \cos \theta = c$, then the value of $a \cos \theta - b \sin \theta$ is
- a. $\sqrt{a^2 + b^2 - c^2}$
 - b. $\sqrt{a^2 + b^2 + c^2}$

c. $\sqrt{a^2 - b^2 + c^2}$

d. None of these

6. Choose the correct option and justify your choice: $\frac{2 \tan 30^\circ}{1 - \tan^2 30^\circ}$

a. $\cos 60^\circ$

b. $\sin 30^\circ$

c. $\sin 60^\circ$

d. $\tan 60^\circ$

7. A kite is flying at a height of 200 m above the ground. The string attached to the kite is temporarily tied to a point on the ground. The inclination of the string with the ground is 45° . The length of the string, assuming that there is no slack in the string is

a. 100 m

b. 200 m

c. $200\sqrt{2}$ m

d. $100\sqrt{2}$ m

8. The co-ordinates of the mid-point of the line joining the points $(3p, 4)$ and $(-2, 4)$ are $(5, p)$. The value of 'p' is

a. 1

b. 4

c. 2

d. 3

9. If the co-ordinates of a point are $(-5, 11)$, then its abscissa is

a. -5

b. 11

c. 5

d. - 11

10. Two dice are thrown simultaneously. The probability of getting a doublet is

a. $\frac{1}{6}$

b. $\frac{1}{2}$

c. $\frac{2}{3}$

d. $\frac{1}{36}$

11. Fill in the blanks:

The TSA of a solid hemisphere of diameter 2cm is _____.

12. Fill in the blanks:

The product of the zeroes of $-2x^2 + kx + 6$ is _____.

OR

Fill in the blanks:

The product of the zeroes of $-2x^2 + kx + 6$ is _____.

13. Fill in the blanks:

$\triangle ABC$ and $\triangle DEF$ are similar. Area of $\triangle ABC$ is 9cm^2 and Area of $\triangle DEF$ is 64cm^2 . If $DE = 5.1\text{cm}$, then the value of AB is _____.

14. Fill in the blanks:

1, 4, 9 form a sequence in which next two terms are _____.

15. Fill in the blanks:

If the vertices of a triangle have integral coordinates, then the triangle cannot be _____ triangle.

16. Can we have any $n \in \mathbb{N}$, where 4^n ends digit zero?

17. In Fig. if $\angle A = \angle C$, then prove that $\triangle AOB \sim \triangle COD$.

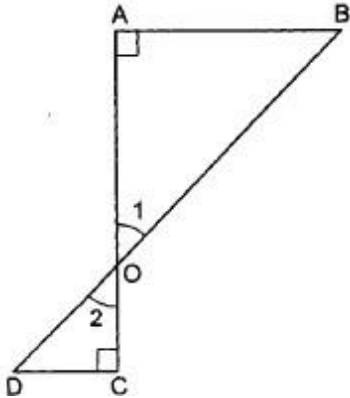

18. If the sum of first k terms of an A.P. is $3k^2 - k$ and its common difference is 6. What is the first term?

OR

What is 18th term of the sequence defined by $a_n = \frac{n(n-3)}{n+4}$.

19. Two tangents making an angle of 60° between them are drawn to a circle of radius $\sqrt{3}$ cm then find the length of each tangent.

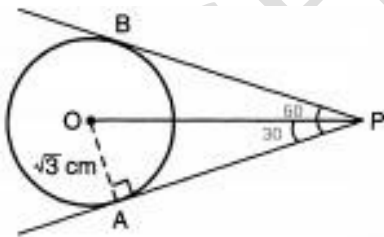

20. Determine whether the given quadratic equation has real roots or not.

$$x^2 - 2x + 1 = 0$$

Section B

21. A box contains 12 balls out of which x are black. If one ball is drawn at random from the box, what is the probability that it will be a black ball? If 6 more black balls are put in the box, the probability of drawing a black ball is now double of what it was

before. Find x .

22. Find the value of k for which the roots are real and equal of equation:

$$4x^2 - 2(k + 1)x + (k + 4) = 0$$

23. In fig. if $AB \parallel DC$ and AC and PQ intersect each other at the point O , prove that $OA \times CQ = OC \times AP$.

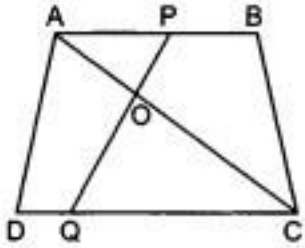

OR

Corresponding sides of two similar triangles are in the ratio of $2 : 3$. If the area of the smaller triangle is 48 cm^2 , find the area of the larger triangle.

24. Vijay lives in a flat in a multi-story building. His driving was rough so his father keeps eye on his driving. Once he drives from his house to Faridabad. His father was standing on the top of the building at point A as shown in the figure. At point C , the angle of depression of a car from the building was 60° . After accelerating 20 m from point C , Vijay stops at point D to buy ice-cream and the angle of depression changed to 30° .

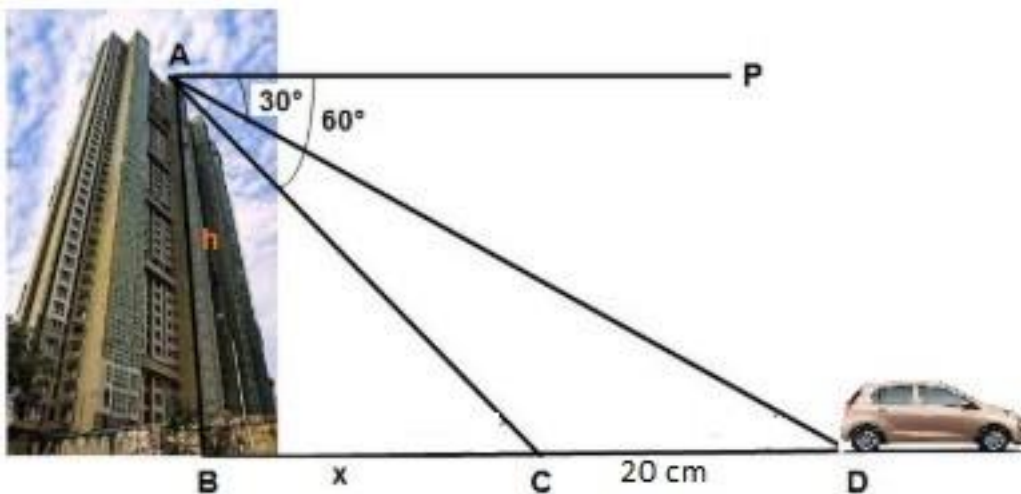

By analysing the above given situation answer the following questions:

- i. Find the value of x .
- ii. Find the height of the building AB.

25. A quadrilateral ABCD is drawn to circumscribe a circle. Prove that $AB + CD = AD + BC$

OR

If PA and PB are tangents drawn from external point P such that $PA = 10\text{cm}$ and $\angle APB = 60^\circ$, find the length of chord AB.

26. A farmer used to irrigate his land during summer on a regular basis to grow his crops and save them from dry weather. To irrigate his land he built a tube well in his field. The tube well has a rectangular tank and a pipe that is used to fill this tank. The dimensions of this tube well system are:

Water is flowing at the rate of 5 km/hr through a pipe of diameter 14 cm into a rectangular tank which is 50 m long and 44 m wide.

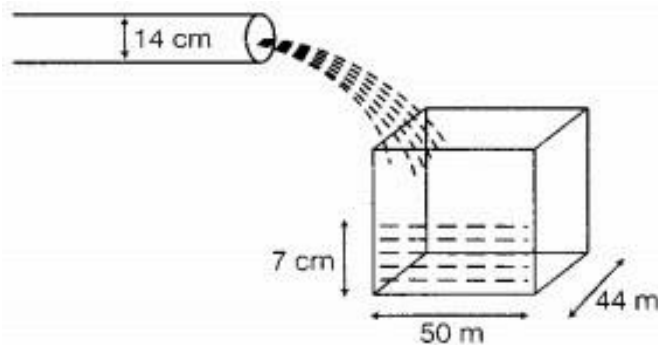

After reading the above given information, answer the following questions:

- i. The volume of the water flowing through the cylindrical pipe in x hours.
- ii. Determine the time in which the level of the water in the tank will rise by 7 cm.

Section C

27. Prove that $\sqrt{5} + \sqrt{3}$ is irrational number.

OR

Write the HCF and LCM of smallest odd composite number and the smallest odd prime number. If an odd number p divides q^2 , then will it divide q^3 also? Explain.

28. In an A.P., if the 5th and 12th terms are 30 and 65 respectively, what is the sum of first

20 terms?

29. Find the values of a and b for which the following system of equations has infinitely many solutions:

$$2x + 3y = 7$$

$$2ax + ay = 28 - by$$

OR

Solve $2x + 3y = 11$ and $2x - 4y = -24$ and hence find the value of 'm' for which $y = mx + 3$.

30. Divide the polynomial $f(x) = 30x^4 + 11x^3 - 82x^2 - 12x + 48$ by $3x^2 + 2x - 4$. Also, find the quotient and remainder.
31. Name the type of quadrilateral formed, if any, by the following points, and give reasons for your answer: $(-3, 5)$, $(3, 1)$, $(0, 3)$, $(-1, -4)$

32. Prove the trigonometric identity:

$$\sec^6\theta = \tan^6\theta + 3\tan^2\theta \sec^2\theta + 1$$

OR

If $\sec \theta + \tan \theta = p$, find the value of $\operatorname{cosec} \theta$.

33. The radius of a circle with centre O is 5 cm (fig.). Two radii OA and OB are drawn at right angles to each other. Find the areas of the segments made by the chord AB (Take $\pi = 3.14$)

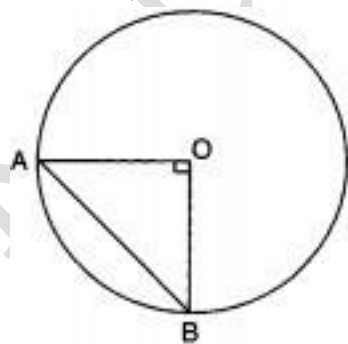

34. The age-wise participation of students in the Annual Function of a school is shown in the following distribution.

Age(in years)	5 - 7	7 - 9	9 - 11	11 - 13	13 - 15	15 - 17	17 - 19
Number of students	x	15	18	30	50	48	x

Find the missing frequencies when the sum of frequencies is 181. Also, find the mode of the data.

Section D

35. Construct an isosceles triangle ABC with base $BC = 6$ cm, $AB = AC$ and $\angle A = 90^\circ$. Draw another similar triangle whose sides are $\frac{4}{5}$ times of the sides of $\triangle ABC$. Justify your construction.

OR

Draw a circle of radius 2 cm with centre O and take a point P outside the circle such that $OP = 6.5$ cm. From P, draw two tangents to the circle.

36. Sides AB and AC and median AD of a triangle ABC are respectively proportional to sides PQ and PR and median PM of another triangle PQR. Prove that $\triangle ABC \sim \triangle PQR$.

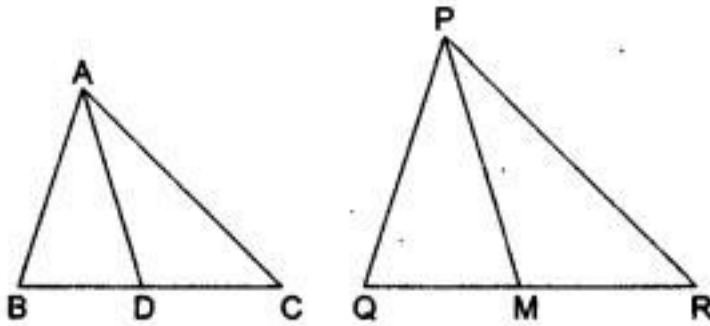

37. Solve the following system of equations graphically:

$$x + 2y - 7 = 0$$

$$2x - y - 4 = 0$$

OR

One says, "Give me a hundred rupee, friend! I shall then become twice as rich as you are." The other replies, "If you give me ten rupees, I shall be six times as rich as you are." Tell me how much money both have initially?

38. A friction clutch is in the form of a frustum of a cone, the diameter of the ends being 32 cm and 20 cm and length 8 cm. Find its bearing surface and volume.

OR

The difference between the sides at right angles in a right-angled triangle is 14 cm. The area of the triangle is 120 cm^2 . Calculate the perimeter of the triangle.

39. A vertical tower stands on a horizontal plane and is surmounted by a flag-staff of height 7 m. From a point on the plane, the angle of elevation of the bottom of the flagstaff is 30° and that of the top of the flag-staff is 45° . Find the height of the tower.
40. In annual day of a school, age-wise participation of students is shown in the following frequency distribution:

Age of student (in years)	5-7	7-9	9-11	11-13	13-15	15-17	17-19
Number of students	20	18	22	25	20	15	10

Draw a less than type' ogive for the above data and from it find the median age.

CBSE Class 10th Mathematics Standard
Sample Paper - 01

Solution

Section A

1. (d)

$$\frac{77}{210}$$

Explanation:

$$\frac{77}{210} = \frac{11}{30} = \frac{11}{2 \times 3 \times 5}$$

Because non-terminating repeating decimal expansion should have the denominator other than 2 or 5.

2. (c)

600

Explanation:

$$24 = 2^3 \times 3$$

$$60 = 2^2 \times 3 \times 5$$

$$150 = 2 \times 3 \times 5^2$$

$$\therefore LCM(24, 60, 150) = 2^3 \times 3 \times 5^2 = 600$$

3. (d) 88

Explanation:

Marks	130- 135	135- 140	140- 145	145- 150	150- 155	155- 160	160- 165
Frequency	10	15	18	22	23	8	4
Cumulative Frequency	10	25	43	65	88	96	100

Therefore, cumulative frequency of the class interval 150 – 155 is 88.

4. (b) 5

Explanation:

Let the number of wickets taken by Srinath be x then the number of wickets taken by Kumble will be $2x - 3$

According to question, $x(2x - 3) = 20$

$$\Rightarrow 2x^2 - 3x - 20 = 0$$

$$\Rightarrow 2x^2 - 8x + 5x - 20 = 0$$

$$\Rightarrow 2x(x - 4) + 5(x - 4) = 0$$

$$\Rightarrow (x - 4)(2x + 5) = 0$$

$$\Rightarrow x - 4 = 0 \text{ and } 2x + 5 = 0$$

$$\Rightarrow x = 4 \text{ and } x = \frac{-5}{2} \text{ [} x = \frac{-5}{2} \text{ is not possible]}$$

Therefore, number of wickets taken by Srinath is 4.

Then number of wickets taken by Kumble = $2 \times 4 - 3 = 5$

5. (a)

$$\sqrt{a^2 + b^2 - c^2}$$

Explanation:

Given: $a \sin \theta + b \cos \theta = c$

Squaring both sides, we get

$$\Rightarrow a^2 \sin^2 \theta + b^2 \cos^2 \theta + 2ab \sin \theta \cos \theta = c^2$$

$$\Rightarrow a^2 (1 - \cos^2 \theta) + b^2 (1 - \sin^2 \theta) + 2ab \sin \theta \cos \theta = c^2$$

$$\Rightarrow a^2 - a^2 \cos^2 \theta + b^2 - b^2 \sin^2 \theta + 2ab \sin \theta \cos \theta = c^2$$

$$\Rightarrow a^2 \cos^2 \theta - b^2 \sin^2 \theta - 2ab \sin \theta \cos \theta = a^2 + b^2 - c^2$$

$$\Rightarrow (a \cos \theta - b \sin \theta)^2 = a^2 + b^2 - c^2$$

$$\Rightarrow a \cos \theta - b \sin \theta = \sqrt{a^2 + b^2 - c^2}$$

6. (d) $\tan 60^\circ$

Explanation:

$$\begin{aligned} & \frac{2 \tan 30^\circ}{1 - \tan^2 30^\circ} \\ &= \frac{2 \times \frac{1}{\sqrt{3}}}{1 - \left(\frac{1}{\sqrt{3}}\right)^2} = \frac{\frac{2}{\sqrt{3}}}{1 - \frac{1}{3}} \\ &= \frac{\frac{2}{\sqrt{3}}}{\frac{2}{3}} = \frac{2}{\sqrt{3}} \times \frac{3}{2} = \sqrt{3} = \tan 60^\circ \end{aligned}$$

7. (c) $200\sqrt{2}$ m

Explanation:

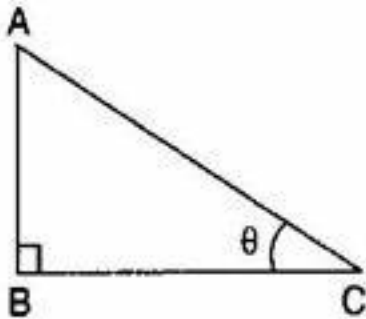

Here, in triangle ABC, Height of the slide = $AB = 200$ m

Angle of elevation = $\theta = 45^\circ$ To find: Length of the string = AC

$$\therefore \sin 45^\circ = \frac{AB}{AC}$$

$$\Rightarrow \frac{1}{\sqrt{2}} = \frac{200}{AC}$$

$$\Rightarrow AC = 200\sqrt{2} \text{ m}$$

8. (b) 4

Explanation:

Let the coordinates of midpoint $O(5, p)$ is equidistance from the points $A(3p, 4)$ and $B(-2, 4)$. (because O is the mid-point of AB)

$$\therefore 5 = \frac{3p-2}{2} \Rightarrow 3p - 2 = 10$$

$$\Rightarrow 3p = 12 \Rightarrow p = 4$$

$$\text{Also } p = \frac{4+4}{2} \Rightarrow p = 4$$

9. (a) -5

Explanation:

Since x -coordinate of a point is called abscissa.

Therefore, abscissa is -5 .

10. (a) $\frac{1}{6}$

Explanation:

Doublet means getting same number on both dice simultaneously

Doublets = (1, 1), (2, 2), (3, 3), (4, 4), (5, 5), (6, 6)

Number of possible outcomes = 6

Total number of ways to throw a dice = 36

Probability of getting a doublet = $\frac{6}{36} = \frac{1}{6}$

11. $3\pi \text{ cm}^2$

12. -3 OR -3

13. $AB = 1.91\text{cm}$

14. 16, 25

15. equilateral triangle

16. If a number ends with zero then it is divisible by 5.

For unit's digit to be 0, then 4^n should have 2 and 5 as its prime factors, but $4^n = (2^2)^n = 2^{2n}$.

As $n \in \mathbb{N}$ we take $n=1,2,3,4\dots$ etc

So above becomes $4^1, 4^2 \dots$ etc

As it does not contain 5 as one of its prime factors.

Therefore, 4^n will not end with digit 0 for $n \in \mathbb{N}$.

17. In triangles AOB and COD, we obtain

$$\angle A = \angle C \text{ (Given)}$$

and, $\angle 1 = \angle 2$ [Vertically opposite angles]

Therefore, by AA- criterion of similarity, we obtain
 $\Delta AOB \sim \Delta COD$

18. Let the sum of k terms of A.P. is $S_n = 3k^2 - k$

Now k^{th} term of A.P = $S_n - S_{n-1}$

$$\begin{aligned}a_k &= (3k^2 - k) - [3(k-1)^2 - (k-1)] \\&= (3k^2 - k) - [3(k^2 - 2k + 1) - (k-1)] \\&= 3k^2 - k - [3k^2 - 6k + 3 - k + 1] \\&= 3k^2 - k - [3k^2 - 7k + 4] \\&= 3k^2 - k - 3k^2 + 7k - 4 \\&= 6k - 4 \\ \text{first term} = a &= 6 \times 1 - 4 = 6 - 4 = 2\end{aligned}$$

OR

We have to find the 18th term of the sequence defined by $a_n = \frac{n(n-3)}{n+4}$.

We have, $a_n = \frac{n(n-3)}{n+4}$

Putting $n=18$, we get

$$a_{18} = \frac{18 \times (18-3)}{18+4} = \frac{18 \times 15}{22} = \frac{135}{11}$$

$$19. \tan 30^\circ = \frac{OA}{AP}$$

$$\Rightarrow \frac{1}{\sqrt{3}} = \frac{\sqrt{3}}{AP}$$

$$\Rightarrow AP = 3$$

$$\therefore AP = BP = 3\text{cm}$$

$$20. x^2 - 2x + 1 = 0$$

Now, Discriminant $D = (-2)^2 - 4 \times 1 \times 1 = 4 - 4 = 0$

For real roots, discriminant should be greater than or equal to zero, so the given equation has real roots.

Section B

21. There are 12 balls in the box.

Therefore, the total number of favourable outcomes = 12

The number of favourable outcomes = x

$$\text{Probability of the event} = \frac{\text{Number of favourable outcomes}}{\text{Total number of possible outcomes}}$$

$$\text{Therefore } P_1 = P(\text{Getting a black ball}) = \frac{x}{12}$$

If 6 more balls put in the box, then

$$\text{Total number of favourable outcomes} = 12 + 6 = 18$$

$$\text{And Number of favourable outcomes} = x + 6$$

$$\therefore P_2 = P(\text{Getting a black ball}) = \frac{x+6}{18}$$

According to question, $P_2 = 2P_1$

$$\begin{aligned} \frac{x+6}{18} &= 2 \times \frac{x}{12} \\ \frac{x+6}{18} \times \frac{12}{x} &= 2 \\ x &= 3 \end{aligned}$$

22. The given equation is $4x^2 - 2(k+1)x + (k+4) = 0$

It has real and equal roots, so $D = 0$

$$b^2 - 4ac = 0$$

$$[-2(k+1)]^2 - 4 \times 4(k+4) = 0$$

$$4(k+1)^2 - 16(k+4) = 0$$

$$4k^2 + 8k + 4 - 16k - 64 = 0$$

$$4k^2 - 8k - 60 = 0$$

$$k^2 - 2k - 15 = 0$$

$$k^2 - 5k + 3k - 15 = 0$$

$$k(k-5) + 3(k-5) = 0$$

$$(k-5)(k+3) = 0$$

$$k = 5, -3$$

23. According to the question, we are given that,

$$AB \parallel DC$$

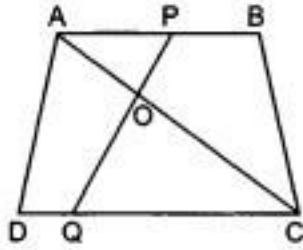

In $\triangle APO$ and $\triangle CQO$, we have,

$$\angle A = \angle C$$

$$\angle P = \angle Q \text{ (Alternate interior angles)}$$

$$\triangle APO \sim \triangle CQO \text{ (AA similarity)}$$

$$\frac{OA}{OC} = \frac{AP}{CQ} \Rightarrow OA \times CQ = OC \times AP$$

OR

We know that, if two triangles are similar, then, the ratio of the areas is the square of the ratio of their corresponding sides.

Since $\triangle ABC \sim \triangle DEF$, therefore by above theorem, we have,

$$\frac{\text{ar}(\triangle ABC)}{\text{ar}(\triangle DEF)} = \left(\frac{AB}{DE}\right)^2$$

$$\text{But, } AB : DE = 2 : 3 \text{ (Given)}$$

$$\text{and ar}(\triangle ABC) \text{ (smaller)} = 48 \text{ cm}^2$$

$$\therefore \frac{48}{\text{ar}(\triangle DEF)} = \left(\frac{2}{3}\right)^2$$

$$\Rightarrow \text{ar}(\triangle DEF) = \frac{48 \times 9}{4} = 108 \text{ cm}^2$$

24. The above figure can be redrawn as shown below:

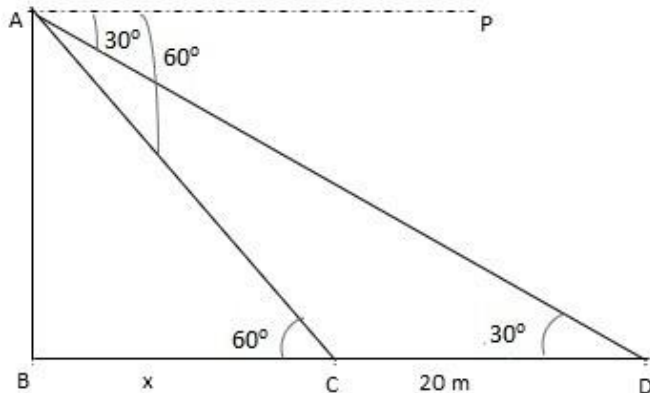

i. From the figure,

let $AB = h$ and $BC = x$

In $\triangle ABC$,

$$\tan 60 = \frac{AB}{BC} = \frac{h}{x}$$

$$\sqrt{3} = \frac{h}{x}$$

$$h = \sqrt{3} x \dots (i)$$

In $\triangle ABD$,

$$\tan 30 = \frac{AB}{BD} = \frac{h}{x+20}$$

$$\frac{1}{\sqrt{3}} = \frac{\sqrt{3}x}{x+20} \text{ [using (i)]}$$

$$x + 20 = 3x$$

$$x = 10\text{m}$$

ii. Height of the building, $h = \sqrt{3} x = 10\sqrt{3} = 17.32 \text{ m}$

25. We know that the tangent segments from an external point to a circle are equal

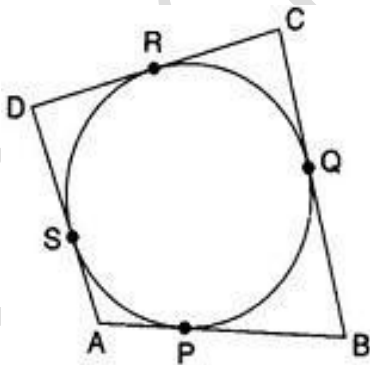

$$\therefore AP = AS \dots (1)$$

$$BP = BQ \dots (2)$$

$$CR = CQ \dots (3)$$

$$DR = DS \dots (4)$$

Adding (1), (2), (3) and (4), we get

$$(AP + BP) + (CR + DR) = (AS + BQ + CQ + DS)$$

$$\Rightarrow AB + CD = (AS + DS) + (BQ + CQ)$$

$$\Rightarrow AB + CD = AD + BC$$

OR

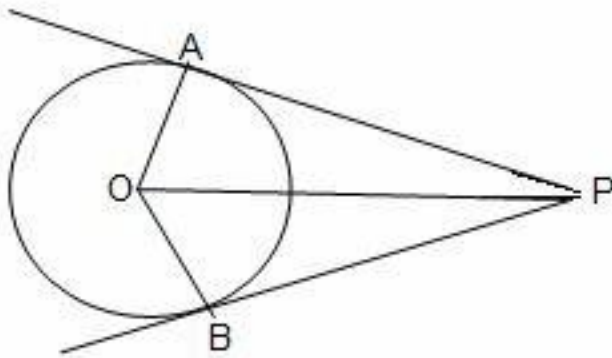

$$\therefore \angle APB = 60^\circ$$

$$\angle AOB = 120^\circ [\text{O is centre of circle}]$$

$$\angle OAB = \angle OBA = 30^\circ$$

$$\therefore \angle PAB = 60^\circ, \angle PBA = 60^\circ$$

$\therefore \triangle PAB$ is equilateral triangle

$$\therefore AB = PA = 10 \text{ cm}$$

26. According to question,

Diameter of the pipe = 14 cm

Thus, Radius of the pipe = 7 cm

Now, the volume of the water flowing through the cylindrical pipe in 1 hour = $\pi r^2 h$

Clearly, the water column forms a cylinder whose radius $r = \frac{14}{2} \text{ cm} = \frac{7}{100} \text{ m}$

and Length = $h = 5000x \text{ m}$

i. Volume of the water flowing through the cylindrical pipe in x hours

$$\begin{aligned} &= \pi r^2 h = \frac{22}{7} \times \left(\frac{7}{100}\right)^2 \times 5000x \text{ m}^3 = \frac{22}{7} \times \frac{7}{100} \times \frac{7}{100} \times 5000x \\ &= 77x \text{ m}^3 \end{aligned}$$

ii. Volume of the water that falls into the tank in x hours = $50 \times 44 \times \frac{7}{100} = 154x \text{ m}^3$

Volume of the water flowing through the cylindrical pipe in x hours = Volume of

the water that falls in the tank in x hours

$$\Rightarrow 77x = 154$$

$$\Rightarrow x = \frac{154}{77} = 2$$

Hence, the level of water in the tank will rise by 7 cm in 2 hours.

Section C

27. Let $\sqrt{5} + \sqrt{3}$ be rational number equal to $\frac{a}{b}$. there exist co-prime integers a and b such that

$$\sqrt{5} + \sqrt{3} = \frac{a}{b}$$

$$\Rightarrow \sqrt{5} = \frac{a}{b} - \sqrt{3}$$

$$\Rightarrow (\sqrt{5})^2 = \left(\frac{a}{b} - \sqrt{3}\right)^2 \text{ [Squaring both sides] we get,}$$

$$\Rightarrow 5 = \frac{a^2}{b^2} - \frac{2a\sqrt{3}}{b} + 3$$

$$\Rightarrow 2 = \frac{a^2}{b^2} - \frac{2\sqrt{3}a}{b}$$

$$\sqrt{3} = (a^2 - 2b^2) \frac{b}{2ab}$$

Since a,b are integers, therefore $(a^2 - 2b^2) \frac{b}{2ab}$ is a rational number which is a contradiction as $\sqrt{3}$ is an irrational number.

Hence, $\sqrt{5} + \sqrt{3}$ is irrational.

OR

Smallest odd composite number = 9

and smallest odd prime number = 3

HCF of 9 and 3 = 3 and LCM of 9 and 3 = 9

Now, if an odd number p divides q^2 , then p is one of the factors of q^2 ,

i.e. $q^2 = pm$, for some integer m (i)

Now, $q^3 = q^2 \times q$

$$\Rightarrow q^3 = pm \times q$$

$$\Rightarrow q^3 = p(mq) \text{ [from Eq(i)]}$$

$\Rightarrow p$ is a factor of q^3 also $\Rightarrow p$ divides q^3 .

28. Let first term be a and common difference be d

Given 5th term = 30

$$\Rightarrow a + (5 - 1)d = 30$$

$$\Rightarrow a + 4d = 30 \dots\dots (i)$$

and, 12th term = 65

$$\Rightarrow a + (12 - 1)d = 65$$

$$\Rightarrow a + 11d = 65 \dots\dots (ii)$$

Subtracting equation (i) from equation (ii)

$$a + 11d - a - 4d = 65 - 30$$

$$\Rightarrow 7d = 35$$

$$\Rightarrow d = \frac{35}{7} = 5$$

Putting value of d in equation (i)

$$a + 4 \times 5 = 30$$

$$\Rightarrow a = 30 - 20 = 10$$

$$\therefore \text{Sum of first 20 terms} = \frac{n}{2}[2a + (n - 1)d]$$

$$= \frac{20}{2}[2 \times 10 + (20 - 1) \times 5]$$

$$= 10[20 + 95]$$

$$= 10 \times 115$$

$$= 1150$$

29. The given system of equations may be written as

$$2x + 3y - 7 = 0$$

$$2ax + ay + by - 28 = 0 \Rightarrow 2ax + (a + b)y - 28 = 0$$

This system of equations is of the form

$$a_1x + b_1y + c_1 = 0$$

$$a_2x + b_2y + c_2 = 0$$

where, $a_1 = 2$, $b_1 = 3$, $c_1 = -7$

And, $a_2 = 2a$, $b_2 = a + b$, $c_2 = -28$

For the system of equations to have infinite solutions,

$$\frac{a_1}{a_2} = \frac{b_1}{b_2} = \frac{c_1}{c_2}$$

$$\Rightarrow \frac{2}{2a} = \frac{3}{a+b} = \frac{-7}{-28}$$

$$\Rightarrow \frac{1}{a} = \frac{3}{a+b} = \frac{1}{4}$$

$$\text{Now, } \frac{1}{a} = \frac{1}{4}$$

$$\Rightarrow a = 4$$

$$\text{And, } \frac{1}{a} = \frac{3}{a+b}$$

$$\Rightarrow a + b = 3a$$

$$\Rightarrow 2a = b$$

$$\Rightarrow 2 \times 4 = b$$

$$\Rightarrow b = 8$$

Hence, the given system of equations will have infinite number of solutions for $a = 4$ and $b = 8$.

OR

The given pair of linear equations

$$2x + 3y = 11 \dots\dots (1)$$

$$2x - 4y = -24 \dots\dots (2)$$

From equation (1), $3y = 11 - 2x$

$$\Rightarrow y = \frac{11-2x}{3}$$

Substituting this value of y in equation (2), we get

$$2x - 4\left(\frac{11-2x}{3}\right) = -24$$

$$\Rightarrow 6x - 44 + 8x = -72$$

$$\Rightarrow 14x - 44 = -72$$

$$\Rightarrow 14x = 44 - 72$$

$$\Rightarrow 14x = -28$$

$$\Rightarrow x = -\frac{28}{14} = -2$$

Substituting this value of x in equation (1), we get

$$y = \frac{11-2(-2)}{3} = \frac{11+4}{3} = \frac{15}{3} = 5$$

Verification, Substituting $x = -2$ and $y = 5$, we find that both the equations (1) and (2) are satisfied as shown below:

$$2x + 3y = 2(-2) + 3(5) = -4 + 15 = 11$$

$$2x - 4y = 2(-2) - 4(5) = -4 - 20 = -24$$

This verifies the solution,

$$\text{Now, } y = ax + c$$

$$\begin{aligned} \Rightarrow 5 &= m(-2) + 3 \\ \Rightarrow -2m &= 5 - 3 \\ \Rightarrow -2m &= 2 \\ \Rightarrow m &= \frac{2}{-2} = -1 \end{aligned}$$

30. Using long division method, we obtain

$$\begin{array}{r} 3x^2 + 2x - 4 \overline{) 30x^4 + 11x^3 - 82x^2 - 12x + 48} \quad (10x^2 - 3x - 12) \\ \underline{30x^4 + 20x^3 - 40x^2} \\ -9x^3 - 42x^2 - 12x + 48 \\ \underline{-9x^3 - 6x^2 + 12x} \\ +36x^2 - 24x + 48 \\ \underline{-36x^2 - 24x + 48} \\ +0 \\ \hline 0 \end{array}$$

Clearly, quotient $q(x) = 10x^2 - 3x - 12$ and remainder $r(x) = 0$.

Also,

$$\begin{aligned} g(x)q(x) + r(x) &= (3x^2 + 2x - 4)(10x^2 - 3x - 12) + 0 \\ &= 3x^2(10x^2 - 3x - 12) + 2x(10x^2 - 3x - 12) - 4(10x^2 - 3x - 12) + 0 \\ &= 30x^4 - 9x^3 - 36x^2 + 20x^3 - 6x^2 - 24x - 40x^2 + 12x + 48 + 0 \\ &= 30x^4 - 9x^3 + 20x^3 - 36x^2 - 6x^2 - 40x^2 - 24x + 12x + 48 + 0 \\ &= 30x^4 + 11x^3 - 82x^2 - 12x + 48 \end{aligned}$$

$$\text{i.e. } f(x) = g(x)q(x) + r(x) = 30x^4 + 11x^3 - 82x^2 - 12x + 48 = f(x)$$

or, Dividend = Quotient \times Divisor + Remainder.

31. $(-3, 5), (3, 1), (0, 3), (-1, -4)$

Let $A \rightarrow (-3, 5), B \rightarrow (3, 1), C \rightarrow (0, 3)$ and $D \rightarrow (-1, -4)$

$$\begin{aligned} \text{Then, } AB &= \sqrt{(3 - (-3))^2 + (1 - 5)^2} = \sqrt{(6)^2 + (-4)^2} \\ &= \sqrt{36 + 16} = \sqrt{52} = 2\sqrt{13} \end{aligned}$$

$$BC = \sqrt{(0 - 3)^2 + (3 - 1)^2} = \sqrt{9 + 4} = \sqrt{13}$$

$$CD = \sqrt{(-1 - 0)^2 + (-4 - 3)^2} = \sqrt{1 + 49} = \sqrt{50}$$

$$DA = \sqrt{[(-3) - (-1)]^2 + [5 - (-4)]^2} = \sqrt{4 + 81} = \sqrt{85}$$

$$AC = \sqrt{[0 - (-3)]^2 + (3 - 5)^2} = \sqrt{13}$$

$$BD = \sqrt{(-1 - 3)^2 + (-4 - 1)^2} = \sqrt{41}$$

We see that $BC + AC = AB$

Hence, the points A, B and C are collinear.

So, ABCD is not a quadrilateral.

32. We have to prove that :-

$$\Rightarrow \sec^6\theta = \tan^6\theta + 3\tan^2\theta\sec^2\theta + 1$$

$$\Rightarrow \sec^6\theta - \tan^6\theta = 3\tan^2\theta\sec^2\theta + 1$$

Now, LHS

$$= \sec^6\theta - \tan^6\theta$$

$$= (\sec^2\theta)^3 - (\tan^2\theta)^3$$

$$= (\sec^2\theta - \tan^2\theta) \left[(\sec^2\theta)^2 + \sec^2\theta\tan^2\theta + (\tan^2\theta)^2 \right] \{\text{Since, } a^3 - b^3 = (a - b)(a^2 + ab + b^2)\}$$

$$= 1 \left[\sec^4\theta + \sec^2\theta\tan^2\theta + \tan^4\theta \right] \left[\because \sec^2\theta - \tan^2\theta = 1 \right]$$

$$= \sec^4\theta + \tan^4\theta + \sec^2\theta\tan^2\theta$$

$$= (\sec^2\theta)^2 + (\tan^2\theta)^2 + \sec^2\theta\tan^2\theta$$

Adding and subtracting $2\sec^2\theta\tan^2\theta$

$$= (\sec^2\theta)^2 + (\tan^2\theta)^2 - 2\sec^2\theta\tan^2\theta + 2\sec^2\theta\tan^2\theta + \sec^2\theta\tan^2\theta$$

$$= (\sec^2\theta - \tan^2\theta)^2 + 3\sec^2\theta\tan^2\theta \left[\because (a - b)^2 = a^2 + b^2 - 2ab \right]$$

$$= 1 + 3\sec^2\theta\tan^2\theta \left[\because \sec^2\theta - \tan^2\theta = 1 \right]$$

= RHS

Hence proved

OR

Given,

$$\sec\theta + \tan\theta = p \dots(i)$$

Also, we know that,

$$\sec^2\theta - \tan^2\theta = 1$$

$$\Rightarrow (\sec \theta - \tan \theta)(\sec \theta + \tan \theta) = 1 [\because a^2 - b^2 = (a + b)(a - b)]$$

$$\Rightarrow (\sec \theta - \tan \theta)p = 1 \text{ [using equation (i)]}$$

$$\Rightarrow \sec \theta - \tan \theta = \frac{1}{p} \dots \text{(ii)}$$

(i)+(ii), we get,

$$\sec \theta + \tan \theta + \sec \theta - \tan \theta = p + \frac{1}{p}$$

$$\Rightarrow 2\sec \theta = \frac{p^2 + 1}{p}$$

$$\Rightarrow \sec \theta = \frac{p^2 + 1}{2p}$$

$$\Rightarrow \frac{1}{\cos \theta} = \frac{p^2 + 1}{2p}$$

$$\Rightarrow \cos \theta = \frac{2p}{p^2 + 1} \dots \text{(iii)}$$

Now, we know that,

$$\sin \theta = \sqrt{1 - \cos^2 \theta}$$

put the value of $\cos \theta$ from eq. (iii), we get,

$$\sin \theta = \sqrt{1 - \left(\frac{2p}{p^2 + 1}\right)^2}$$

$$\Rightarrow \sin \theta = \sqrt{1 - \frac{4p^2}{(p^2 + 1)^2}}$$

$$\Rightarrow \sin \theta = \sqrt{\frac{(p^2 + 1)^2 - 4p^2}{(p^2 + 1)^2}}$$

$$\Rightarrow \sin \theta = \sqrt{\frac{p^4 + 1 + 2p^2 - 4p^2}{(p^2 + 1)^2}}$$

$$\Rightarrow \sin \theta = \sqrt{\frac{p^4 + 1 - 2p^2}{(p^2 + 1)^2}}$$

$$\Rightarrow \sin \theta = \sqrt{\frac{(p^2 - 1)^2}{(p^2 + 1)^2}}$$

$$\Rightarrow \sin \theta = \frac{p^2 - 1}{p^2 + 1}$$

$$\operatorname{cosec} \theta = \frac{p^2 + 1}{p^2 - 1} [\because \operatorname{cosec} \theta = \frac{1}{\sin \theta}]$$

$$\text{hence, } \operatorname{cosec} \theta = \frac{1+p^2}{1-p^2}$$

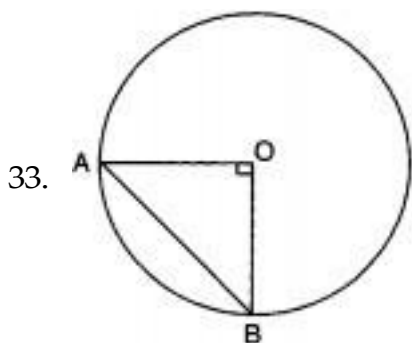

Radius of circle = $r = 5$ cm

Angle of the corresponding sector = $\theta = 90^\circ$

$$\text{Area of the minor segment} = \left[\frac{\pi}{360} \times \theta - \sin \frac{\theta}{2} \cos \frac{\theta}{2} \right] r^2$$

$$= \left[\frac{3.14}{360} \times 90^\circ - \sin 45^\circ \cos 45^\circ \right] \times 5 \times 5$$

$$= \left[\frac{3.14}{4} - \frac{1}{\sqrt{2}} \times \frac{1}{\sqrt{2}} \right] \times 25$$

$$= \left[\frac{3.14}{4} - \frac{1}{2} \right] \times 25$$

$$= \left[\frac{1.57}{2} - \frac{1}{2} \right] \times 25$$

$$= \left[\frac{0.57}{2} \right] \times 25$$

$$= 7.125 \text{ cm}^2$$

$$\text{Area of a circle} = \pi r^2 = 3.14 \times (5)^2 = 78.5 \text{ cm}^2$$

Now, Area of major segment = Area of circle - Area of minor segment

$$= (78.5 - 7.125) \text{ cm}^2$$

$$= 71.375 \text{ cm}^2$$

34. Sum of the frequencies = 181

$$\Rightarrow x + 15 + 18 + 30 + 50 + 48 + x = 181$$

$$\Rightarrow 2x + 161 = 181$$

$$\Rightarrow x = 10$$

Thus, the missing frequencies are 10 and 10.

Clearly, the modal class is 13 - 15, as it has the maximum frequency.

$$\therefore l = 13, h = 2, f_1 = 50, f_0 = 30, f_2 = 48$$

$$\text{Mode, } M_o = l + \left\{ h \times \frac{(f_1 - f_0)}{(2f_1 - f_0 - f_2)} \right\}$$

$$\begin{aligned}
&= 13 + 2 \left\{ \frac{50-30}{2(50)-30-48} \right\} \\
&= 13 + 2 \times \frac{20}{22} \\
&= 13 + 1.81 = 14.81
\end{aligned}$$

Section D

35. Given, An isosceles $\triangle ABC$ with base $BC = 6\text{cm}$, $AB = AC$ and $\angle A = 90^\circ$

Then, $\angle B = \angle C = \frac{1}{2} \times 90^\circ = 45^\circ$

Required, $\triangle A'BC' \sim \triangle ABC$ with the scale factor $\frac{4}{5}$

Steps of construction are as below:

- i. First of all, construct an isosceles triangle $\triangle ABC$ where the base $BC = 6\text{ cm}$, $AB = AC$, $\angle A = 90^\circ$, $\angle B = 45^\circ$ and $\angle C = 45^\circ$
- ii. Through point B, construct an acute angle $\angle CBX$ on the side opposite to the vertex A.
- iii. Mark five points B_1, B_2, B_3, B_4, B_5 on BX such that $BB_1 = B_1B_2 = B_2B_3 = B_3B_4 = B_4B_5$
- iv. Join the points B_5C
- v. From, point B_4 draw $B_4C' \parallel B_5C$ intersecting line segment BC at C'
- vi. Through C' , draw $C'A' \parallel CA$ intersecting AB at A' .

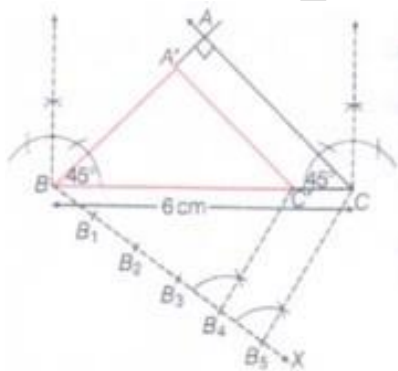

Hence, $\triangle A'BC'$ is the required triangle as per the question.

Justification of the triangle drawn is as below:

By the construction, $B_4C' \parallel B_5C$

Therefore, $\frac{BC'}{C'C} = \frac{4}{5-4} = \frac{4}{1}$

$\Rightarrow \frac{C'C}{BC'} = \frac{1}{4}$

Now, $\frac{BC}{BC'} = \frac{BC'+C'C}{BC'}$

$$\Rightarrow 1 + \frac{C'C}{BC'} = 1 + \frac{1}{4}$$

$$\Rightarrow 1 + \frac{C'C}{BC'} = \frac{5}{4}$$

$$\text{i.e., } \frac{BC}{BC'} = \frac{5}{4}$$

Also $\triangle A'BC' \sim \triangle ABC$ [by AA similarity]

Hence it is proved that, $\frac{A'C'}{AC} = \frac{BC'}{BC} = \frac{A'B}{AB} = \frac{4}{5}$

OR

STEPS OF CONSTRUCTION

1. Draw a circle of radius 2 cm and O as centre.
2. Mark a point P outside the circle such that OP = 6.5 cm.

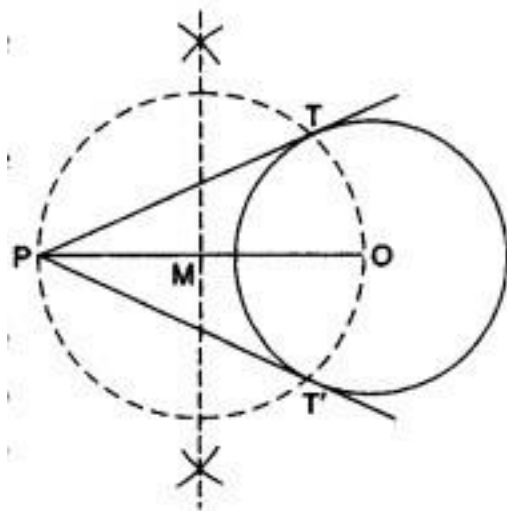

3. Join OP and bisect it at M.
4. Draw a circle with M as centre and radius equal to MP, to intersect the given circle at the points, T and T'.
5. Join PT and PT'.

So, PT and PT' are required tangents.

36. By given condition, we have,

$$\frac{AB}{PQ} = \frac{AC}{PR} = \frac{AD}{PM}$$

To Prove $\triangle ABC \sim \triangle PQR$

Construction: produce AD to E such that AD = AE and Produce PM and N such that PM = MN.

Join EC and NR.

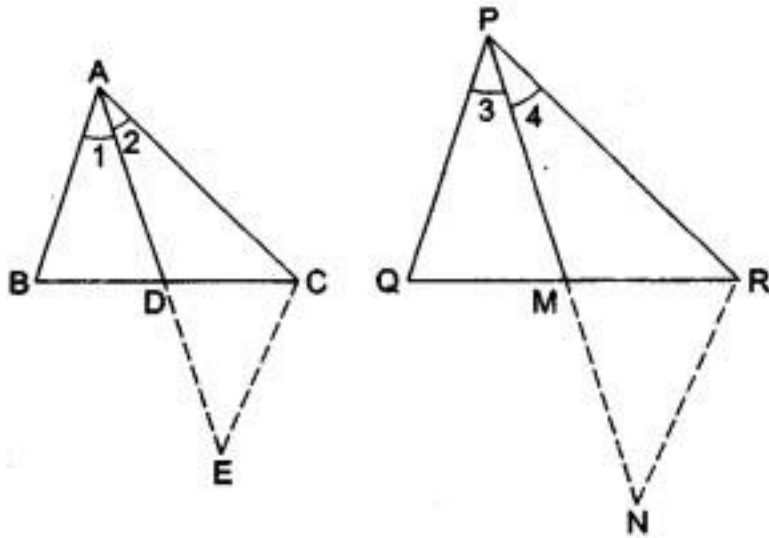

Proof In $\triangle ABD$ and $\triangle ECD$, we have

$BD = CD$ [\because D is the midpoint of BC]

$AD = ED$ [by construction]

$\angle BDA = \angle CDE$ [vertically opposite angles]

$\therefore \triangle ABD \cong \triangle ECD$ [by SAS-congruency].

Therefore, $AB = EC$... (i) [cpct]

Similarly, $\triangle PQM \cong \triangle NRM$

Therefore, $PQ = NR$... (ii) [cpct]

Now, $\frac{AB}{PQ} = \frac{AC}{PR} = \frac{AD}{PM}$ (given)

$\Rightarrow \frac{EC}{NR} = \frac{AC}{PR} = \frac{AD}{PM}$ [using (i) and (ii)]

$\Rightarrow \frac{EC}{NR} = \frac{AC}{PR} = \frac{2AD}{2PM} = \frac{AE}{PN}$ [$\because 2AD = AE, 2PM = PN$]

$\Rightarrow \triangle ACE \sim \triangle PNR$ [SSS-similarity].

$\therefore \angle 2 = \angle 4$

[corresponding angles of similar triangles are equal].

Similarly, $\angle 1 = \angle 3$ [it can be proved by joining BE and QN and showing

$\triangle ABE \sim \triangle PQN$].

$\therefore \angle 1 + \angle 2 = \angle 3 + \angle 4$, i.e, $\angle BAC = \angle QPR$... (iii)

Now, in $\triangle ABC$ and $\triangle PQR$, we have

$\frac{AB}{PQ} = \frac{AC}{PR}$ [given]

$\angle BAC = \angle QPR$ [from (iii)]

$\therefore \triangle ABC \sim \triangle PQR$ [by SAS-similarity].

37. Given equations, $x + 2y - 7 = 0$ and $2x - y - 4 = 0$

Now, $x + 2y - 7 = 0$

$x = 7 - 2y$

When $y = 1 \Rightarrow x = 5$

When $y = 2 \Rightarrow x = 3$

Thus, we have the following table giving points on the line $x + 2y - 7 = 0$

x	5	3
y	1	2

Now, $2x - y - 4 = 0$

$\Rightarrow y = 2x - 4$

When $x = 2$, then $y = 0$

When $x = 0$, then $y = -4$

Thus, we have the following table giving points on the line $2x - y - 4 = 0$

X	2	0
Y	0	-4

Graph:

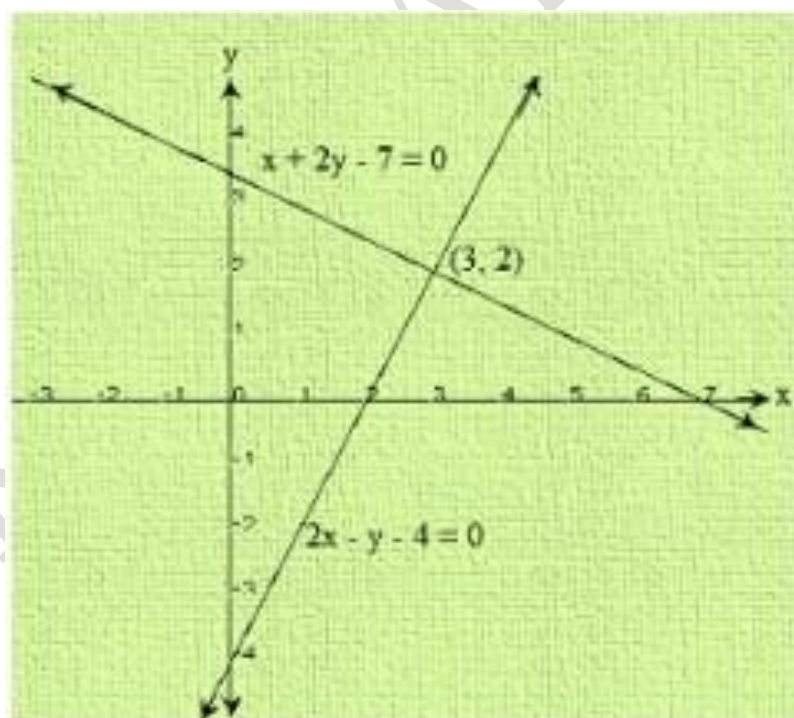

Clearly, two intersect at P (3, 2)

Hence, $x = 3$ and $y = 2$ is the solution of the given system of equations.

OR

Suppose initially, they had Rs x and Rs. y with them respectively.

as per condition given in the question, we obtain

$$x + 100 = 2(y - 100)$$

$$\Rightarrow x + 100 = 2y - 200$$

$$\Rightarrow x - 2y = -300 \dots(i)$$

$$\text{and } 6(x - 10) = (y + 10)$$

$$6x - 60 = y + 10$$

$$\Rightarrow 6x - y = 70 \dots(ii)$$

Multiplying equation (ii) by 2 & then subtracting equation (i) from it, we obtain:-

$$(12x - 2y) - (x - 2y) = 140 - (-300)$$

$$\Rightarrow 11x = 140 + 300$$

$$\Rightarrow 11x = 440$$

$$\Rightarrow x = 40$$

Putting $x = 40$ in equation (i), we obtain

$$40 - 2y = -300$$

$$\Rightarrow 40 + 300 = 2y$$

$$\Rightarrow 2y = 340$$

$$\Rightarrow y = 170$$

Therefore, initially they had Rs 40 and Rs 170 with them respectively.

38. Let $ABB'A'$ be the frustum of a cone of slant height 1 cm.

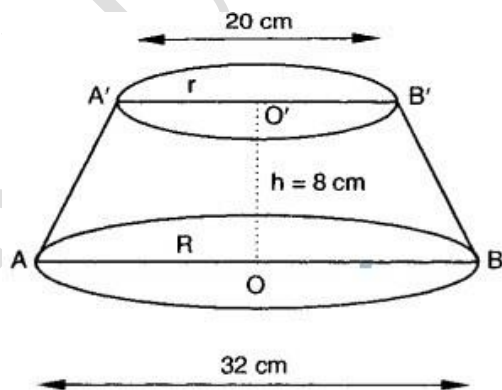

We have,

$$R = 16 \text{ cm, } r = 10 \text{ cm and } h = 8 \text{ cm}$$

$$\begin{aligned}
\therefore l^2 &= h^2 + (R - r)^2 \\
&= (8)^2 + (16 - 10)^2 \\
&= 64 + (6)^2 \\
\Rightarrow l^2 &= 64 + 36 \Rightarrow l = 10\text{cm}
\end{aligned}$$

Bearing surface of the clutch = Lateral surface of the frustum

$$\begin{aligned}
\Rightarrow S &= \pi(R + r)l \\
&= \frac{22}{7} \times (16 + 10) \times 10\text{cm}^2 \\
&= 817.14\text{cm}^2
\end{aligned}$$

$$\begin{aligned}
V &= \frac{1}{3}\pi h (R^2 + Rr + r^2) \\
\Rightarrow V &= \frac{1}{3} \times \frac{22}{7} \times 8 \times (16^2 + 16 \times 10 + 10^2) \text{cm}^3 \\
\Rightarrow V &= \frac{1}{3} \times \frac{22}{7} \times 8 \times (256 + 160 + 100) \text{cm}^3 = \frac{176}{21} \times 516\text{cm}^3 \\
&= 4324.57 \text{cm}^3
\end{aligned}$$

OR

Let the sides containing the right angle be x cm and $(x - 14)$ cm.

$$\text{Then, its area} = \left[\frac{1}{2} \times x \times (x - 14) \right] \text{cm}^2.$$

But according to question it is given that area of a triangle is 120cm^2

$$\begin{aligned}
\therefore \frac{1}{2}x(x - 14) &= 120 \Rightarrow x^2 - 14x - 240 = 0 \\
\Rightarrow x^2 - 24x + 10x - 240 &= 0 \Rightarrow x(x - 24) + 10(x - 24) = 0
\end{aligned}$$

$$\Rightarrow x = 24, -10$$

\therefore one side = 24 cm, and other side = $(24 - 14)$ cm = 10 cm.

$$\text{hypotenuse} = \sqrt{(24)^2 + (10)^2} \text{cm}$$

$$= \sqrt{576 + 100} \text{cm}$$

$$= \sqrt{676} \text{cm} = 26 \text{cm}$$

\therefore perimeter of the triangle = $(24 + 10 + 26)$ cm = 60 cm.

39.

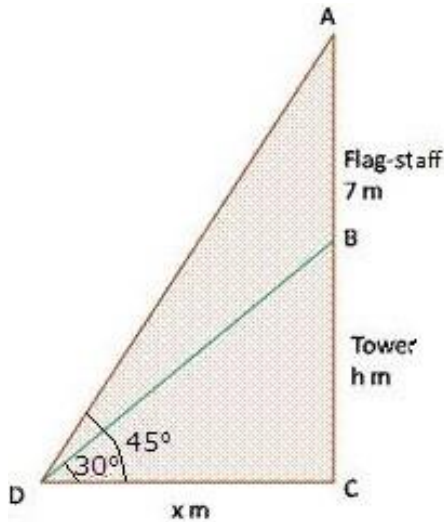

Let us suppose that BC be the height of tower = h m

Suppose DC denotes distance = x m

Now, in $\triangle BCD$

$$\tan 30^\circ = \frac{BC}{DC}$$

$$\Rightarrow \frac{1}{\sqrt{3}} = \frac{h}{x}$$

$$\Rightarrow x = h\sqrt{3} \dots\dots(i)$$

In $\triangle ACD$

$$\tan 45^\circ = \frac{AC}{DC}$$

$$\Rightarrow 1 = \frac{7+h}{x}$$

$$\Rightarrow x = 7 + h$$

$$\Rightarrow h\sqrt{3} - h = 7 \text{ [By Using (i)]}$$

$$\Rightarrow h = \frac{7}{\sqrt{3}-1} \times \frac{\sqrt{3}+1}{\sqrt{3}+1}$$

$$\Rightarrow h = \frac{7(\sqrt{3}+1)}{3-1}$$

$$\Rightarrow h = \frac{7(1.73+1)}{2}$$

$$= \frac{19.11}{2}$$

\therefore Height of tower = 9.555 m.

Thus, the height of the tower is 9.552 m

40.

Students	c.f.
Less than 7	20

Less than 9	38
Less than 11	60
Less than 13	85
Less than 15	105
Less than 17	120
Less than 19	130

Units: x-axis 1 cm = 2; y-axis 1 cm = 10

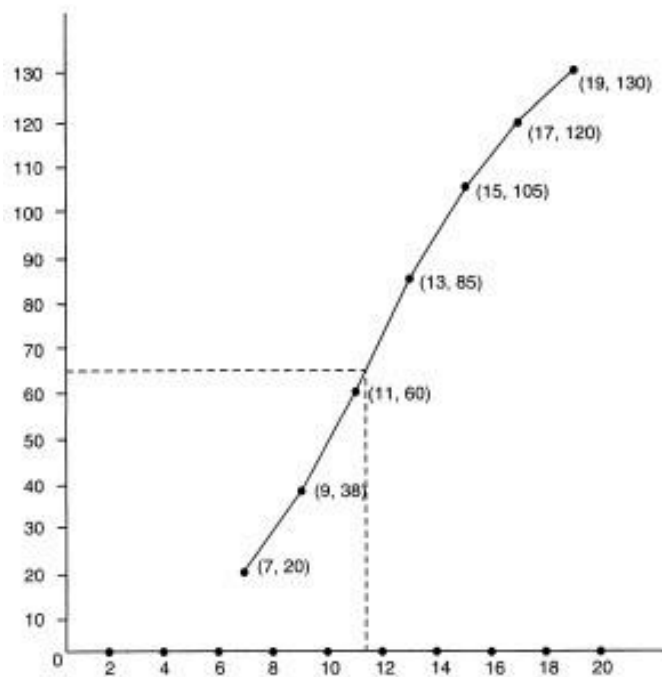

This curve is the required cumulative frequency curve or an ogive of the less than type.

Here, $N = 130$,

$$\text{So, } \frac{N}{2} = \frac{130}{2} = 65$$

Now, we locate the point on the ogive whose ordinate is 65. The x-coordinate corresponding to this ordinate is 11.4.

Hence, the required median on the graph is 11.4.